



OWNER'S MANUAL



Golden Line G500
OWNER'S MANUAL

Edition 11/July 2024



TABLE OF CONTENTS

1. SAFETY INFORMATION	10
Introduction	10
Precautionary symbols.....	11
General information.....	13
Maximum number of persons	14
Maximum loading capacity	14
Distribution of load.....	15
Loading passengers.....	16
Stability and buoyancy.....	18
Engine information.....	18
Risk of flooding and stability	19
Risk of fire or explosion	23
Fire prevention	23
Fuel system	24
Before fueling	26
While fueling	27



Fire-fighting equipment	28
Electrical systems - Safety rules	30
Battery.....	31
Man-overboard prevention and recovery	32
Means of reboarding	33
Safety equipment.....	34
Safety driving rules	36
safety labels	38
2. BOAT IDENTIFICATION	40
Boat's Identification number	40
Builder's plate.....	41
Location of the builder's plate	43
3. BEFORE OPERATING YOUR CRAFT	44
Checklist before departure	44
Weather	45
General	45



TABLE OF CONTENTS

Rules to observe when afloat	46
4. OPERATING THE CRAFT.....	47
Tube inflation	47
Overpressure valve (if fitted).....	52
Motor installation	53
Motor start&stop.....	55
Electrics	57
Battery isolator switch	57
Components of a boat	63
Anchoring, mooring and towing.....	74
Anchoring.....	74
Mooring	75
Towing.....	77
Beaching	79
5. TECHNICAL INFORMATION	80
Technical specification.....	80



Standard and optional equipment.....	82
Compartment chart.....	84
General arrangement of a boat	85
Steering console components.....	87
General view of a boat	89
Electrical schematic diagrams.....	90
6. SERVICE AND MAINTENANCE	92
Cleaning.....	93
Cleaning of tube	94
Plastic preservation	96
Cleaning.....	96
Salt removal	97
Polishing	97
Waxing	97
Cleaning of the underwater part of the hull from deposits.....	98
Antifouling hull protection	98



TABLE OF CONTENTS

Upholstery care.....	99
Acrylic glass windshield care	100
Airtightness of the inflatable tube	101
Maintenance of stainless steel	103
Winterizing and storage.....	103
Regular inspections	104
7. TRAILERING	105
Boat towing.....	108
8. RESPECTING THE ENVIRONMENT	109
9. GRAND'S WARRANTY	110
General	110
Warranty period.....	110
Warranty coverage.....	111
Warranty exclusions	112
Warranty certificate.....	113
FOR YOUR NOTES.....	114



1. SAFETY INFORMATION

INTRODUCTION

Thank you for choosing a Grand boat.

If you need assistance or advice please contact your Grand Dealer or Distributor who has qualified specialists, special tools, original spare parts and accessories and will be happy to assist.

This Manual provides an overview for the safe operation of your Grand boat *and is not intended to teach you how to repair it*. Please take time to read it carefully so as to become familiar with your new boat. Make sure that you fully understand the controls and instructions before operating the boat. Improper operation can be extremely dangerous!

Please, note that most boating-related accidents happen when safety instructions are ignored. We want you to enjoy your experience on your boat so please be sure to take our guidance seriously and comply with safety instructions at all times.

The basic safety rules are stated throughout the Manual, additional precautions are indicated by the special PRECAUTIONARY SYMBOLS:



SAFETY

PRECAUTIONARY SYMBOLS

The following precautionary symbols are used throughout this Manual:



Indicates an imminently hazardous situation that, if not avoided, will result in death or serious injury. This signal word is to be limited to the most extreme situations.



Indicates a potentially hazardous situation that, if not avoided, could result in death or serious injury.



Indicates a potentially hazardous situation that, if not avoided, could result in minor or moderate injury.

Please note that in some countries a boat operating license or other form of authorization may be required.

We strongly recommend that your boat is inspected at least once a year by an authorized Grand agent.



Helmsmen should be familiar with the use of all safety equipment and emergency procedures (e.g. man overboard recovery, towing etc.). We strongly recommend that appropriate training is undertaken from a recognized boating and/or safety organization prior using your boat.

Please note that in some countries it is a mandatory requirement to wear a buoyancy aid.

Some information may not apply to your boat since standard and optional equipment may vary from model to model.

Data sheets and specifications given in this manual relate to the boat's characteristics at the time of publishing. Grand reserve the right to introduce changes in specifications and equipment without notice and without obligation.

We continually work with our customers to improve quality and to ensure you will be completely satisfied with your Grand boat.

If you have any additional questions after reading this manual, please feel free to ask for your dealer.

PLEASE KEEP THIS MANUAL IN A SECURE PLACE, AND HAND IT OVER TO THE NEW OWNER WHEN YOU SELL THE CRAFT.



SAFETY

GENERAL INFORMATION

Name of craft Manufacture: GRAND MARINE. Model: G500.

According to the Recreational Craft Directive 2013/53/EU of the European Parliament and of the Council of 20th November 2013, which is in force, your boat has design category: C, i.e., the craft is designed to operate in the following conditions:

Wind (Beaufort scale) up to and including Force 6;

Significant wave height ($H^{1/3}$, meters) up to and including 2 meters.

Explanatory note:

A watercraft given design category C is considered to be designed for a wind speed up to and including Force 6 and significant wave height up to and including 2 m.



WARNING

BE RESPONSIBLE, TAKE NOTICE OF THESE PARAMETERS WHEN YOU PLAN YOUR NAVIGATION PROGRAM AND DO NOT BOAT IF THE WIND/WAVE CONDITIONS ARE LIKELY TO EXCEED THESE PARAMETERS.



MAXIMUM NUMBER OF PERSONS

The Maximum number of people (adults + children) authorized to be on board according to design standards ISO 14946 and ISO 12217 is given in the technical data sheet in the “TECHNICAL INFORMATION” section.



DO NOT EXCEED THE MAXIMUM RECOMMENDED NUMBER OF PEOPLE. REGARDLESS OF THE NUMBER OF PEOPLE ON BOARD, THE TOTAL WEIGHT OF PEOPLE AND EQUIPMENT MUST NEVER EXCEED THE MAXIMUM RECOMMENDED LOAD. ALWAYS USE THE SEATS/SEATING SPACES PROVIDED.

MAXIMUM LOADING CAPACITY

You can find the maximum load capacity in the “TECHNICAL INFORMATION” section in this Manual. It is also shown on the manufacturer’s plate affixed to the hull. Please note that the maximum load capacity includes the weight of all people onboard, outboard engine, provisions, personal effects, and additional equipment, minus liquids in fixed tanks. Note that excess and unevenly distributed load within the boat can create unstable steering conditions and even loss of control.



SAFETY



WARNING

WHEN LOADING THE CRAFT, NEVER EXCEED THE MAXIMUM RECOMMENDED LOAD. ALWAYS LOAD THE CRAFT CAREFULLY AND DISTRIBUTE LOADS APPROPRIATELY TO MAINTAIN DESIGN TRIM (APPROXIMATELY LEVEL). AVOID PLACING HEAVY WEIGHTS HIGH UP.

DISTRIBUTION OF LOAD

Evenly distribute the load within the boat.



CAUTION

1. POORLY DISTRIBUTED LOADS CAN DESTABILIZE THE BOAT AND MAY RESULT IN A LOSS OF CONTROL.
2. THE CRAFT'S HANDLING WILL CHANGE SIGNIFICANTLY DEPENDING ON THE LOAD CARRIED.
3. BE PARTICULARLY CAREFUL WHEN ACCELERATING OR CHANGING DIRECTION. IT MAY BE NECESSARY TO ADJUST LOAD DISTRIBUTION AND TRIM WHEN NAVIGATION CONDITIONS OR THE CRAFT'S DIRECTION THROUGH WAVES CHANGE.



LOADING PASSENGERS

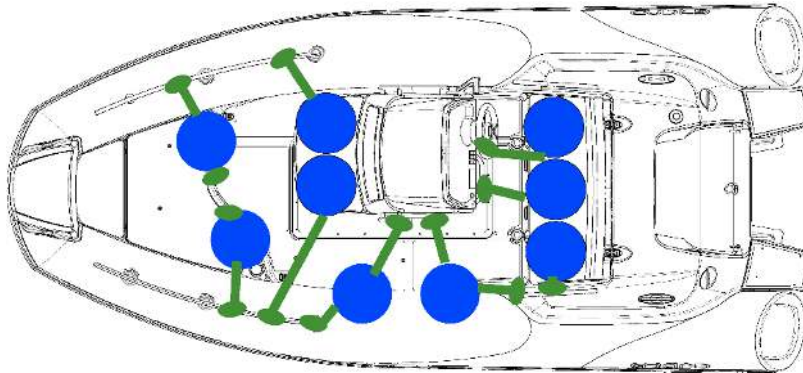

Fig. 1. Recommended seating arrangement for 9 passengers.



Every passenger, including children, should be equipped with an appropriately sized personal flotation device.

**WARNING**

WHEN THE BOAT IS IN MOTION, IT IS CRUCIAL FOR ALL PASSENGERS TO SECURELY HOLD ON TO THE DESIGNATED HANDLES OR HANDHOLDS.

IMPORTANT NOTICE

WEARING NON-SLIP FOOTWEAR IS ADVISED.



SAFETY

IN CASE OF AN ACCIDENT

In case of an accident, do not panic and reassure passengers.

- Be aware that your boat, even if damaged, may provide the best shelter and facilitate your rescue. Never leave the boat whilst it remains afloat. Remember that an inflatable boat, even when full of water, is virtually unsinkable.
- If, after an accident, a tube compartment deflates, bring it inside the boat, restore the load balance to the opposite side of the deflated compartment and return to port at reduced speed.
- In case of a collision or an impact with a floating object, stop to examine the hull, the buoyancy tubes, the motor and its attachments and return to shore at a low speed.
- Signal for help.

Following an accident and before using the craft again, make sure that it is examined by your dealer or a qualified technician and any defects are repaired.



WARNING

NEGLECTING REGULAR INSPECTIONS AND REPAIRS MAY LEAD TO A SERIOUS INJURY OR DAMAGE AND WILL REDUCE THE LIFE OF YOUR BOAT.



STABILITY AND BUOYANCY

The stability and buoyancy of the craft have been thoroughly assessed by the builder in compliance with the requirements of the Recreational Craft Directive 2013/53/EU. The craft builder guarantees that the boat meets all safety criteria during normal operating conditions. However, the person responsible for operating the craft must always keep in mind that the safety of the craft and crew should be their priority at all times and that conditions on the water can change suddenly with little prior notice. Before using your boat, it is strongly recommended that appropriate training is given to all crew members in the safe operation of the craft.

ENGINE INFORMATION

Information about recommended engine capacities, maximum engine capacities, maximum engine weights for each model are given in the technical data sheet of "TECHNICAL INFORMATION" section.



DANGER

NEVER USE A MOTOR WITH A POWER OUTPUT GREATER THAN THE MAXIMUM RECOMMENDED, OR HEAVIER THEN INDICATED ON THE BUILDER'S PLATE. THIS COULD RESULT IN LOSS OF CONTROL.



SAFETY

RISK OF FLOODING AND STABILITY

The drainage system consists of cockpit drainage (two cockpit drain hoses with plugs + valves) and hull drainage (drain plug + bilge pump, which can operate in manual/automatic mode).

COCKPIT DRAINAGE

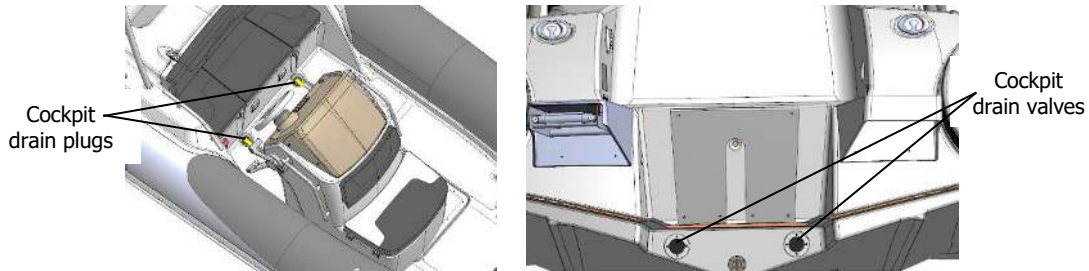

Fig. 2. Cockpit drainage.

	In water at rest	In water in motion	Out of water
Cockpit drain plugs	Closed	Open	Open



CAUTION

WHEN THE BOAT IS ON LAND/DAVIT OR TRAILER, OPEN THE COCKPIT DRAIN PLUGS SO THAT WATER (RAINWATER, FOR INSTANCE) CAN EASILY DRAIN OUT OF THE BOAT THROUGH THE VALVES AND NO DAMAGE TO THE INTERNAL COMPONENTS (E.G. THE BATTERY) WILL OCCUR.



HULL DRAINAGE

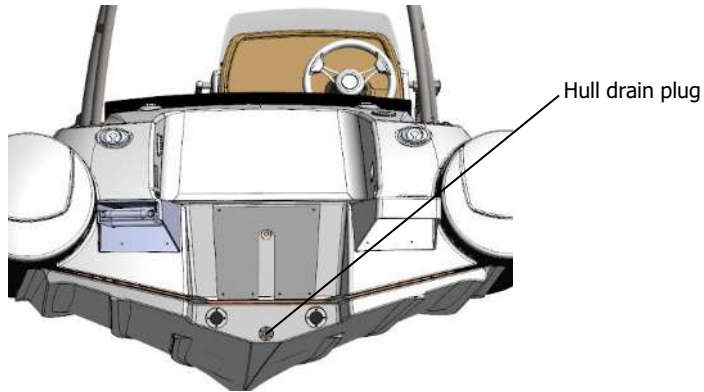

**NEVER OPEN THE HULL
DRAIN PLUG WHEN AFLOAT.**

Fig. 3. Hull drainage.

	In water at rest	In water in motion	Out of water
Hull drain plug	Closed	Closed	Open

To drain the hull unscrew the plug (fig. 3). After removal refit and re-tighten (do not over-tighten) the plug before using the boat.

CAUTION WHEN THE BOAT IS ON LAND/DAVIT OR TRAILER, OPEN THE HULL DRAIN PLUG SO THAT WATER CAN EASILY DRAIN OUT OF THE BOAT.



SAFETY

AUTOMATIC HULL DRAINAGE

The automatic bilge pump serves to pump water out of the bilge area of the boat.

The bilge pump is located inside of additional section of rear locker (fig. 4). For maintenance unscrew and remove plywood plate so that bilge pump is been accessible.



Fig. 4. Bilge pump and its location.



WARNING

THE BILGE PUMP SYSTEM IS NOT DESIGNED FOR DAMAGE CONTROL.



BILGE PUMP SPECIFICATIONS

Capacity 2.3 m³/h (with zero head).

Power 12 V/2.5 A.

Maximum head 2.3 m.

Connection 3/4".

Overall dimensions 17.5x9.5x12 (LxWxH) cm.



Switching the bilge pump on/off is done manually by using the switch located on the steering console and automatically by a built-in mercury-free float type switch.

Check the operation of the bilge pump either by using the switch located on the steering console or by turning the test knob (see also manufacturers' manual), located on the pump in a clockwise direction. Make sure the inlet channels are free from contamination.



CAUTION

CHECK BILGE PUMP REGULARLY TO MAKE SURE IT IS WORKING. CLEAR DEBRIS FROM PUMP INLETS.



SAFETY

RISK OF FIRE OR EXPLOSION

Pay particular attention to the fact that a fuel tank and electrical devices are installed on your boat. This means that there is a risk of explosion or fire caused, for example, by a spark. Be careful and check systems regularly with a view to identifying leaks or corrosion in the fuel tank and possible damage to the electrical wiring.

For information concerning safe operation of the engine consult the manufacturers instruction manual.

FIRE PREVENTION

Consult your Dealer for more detailed information on this subject before operating your boat.

The owner/helmsman of the craft should:

- Inform all crew members about the location and operation of all firefighting equipment.
- Check firefighting equipment at the intervals indicated on each item.
- Replace any used extinguisher with one of same type and rating.



WARNING

NEVER MODIFY ANY OF THE CRAFT'S SYSTEM UNLESS COMPETENT TO DO SO.



FUEL SYSTEM

The fuel system consists of a fuel tank (the volume is given in the technical data sheet), sender and fuel level gauge (optional), filler neck, fuel cap with built-in air vent.

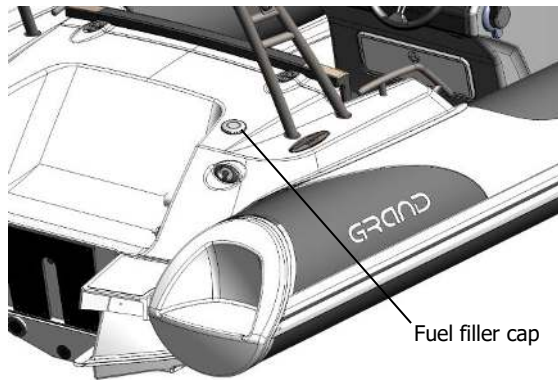

Access to the top part of the fuel tanks, as well to the connections and fuel sensor is provided through the hatch located on the deck and fixed by the screws. To get the possibility to unscrew and then open the hatch, helm and passenger double seat should be removed.

Fig. 5. The location of the fuel filler cap on the rear deck.



DANGER

DO NOT SMOKE OR USE AN OPEN FLAME WHEN FUELING THE BOAT.

AVOID CONTACT OF FLAMMABLE MATERIALS WITH HOT ENGINE PARTS.



SAFETY

VENTILATION OF PETROL TANK COMPARTMENT

Petrol tank compartment has a natural ventilation system. The fuel tank compartment is ventilated by the natural flow of air through ventilation openings (figs. 6-8) to and from the atmosphere. These openings are located at the bow locker and rear storage compartments.

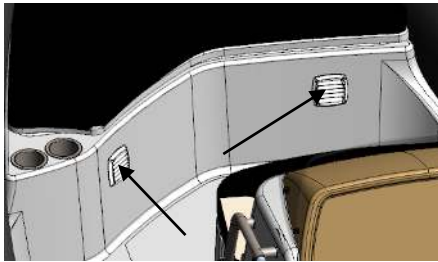

Fig. 6. Ventilation openings on the bow locker.

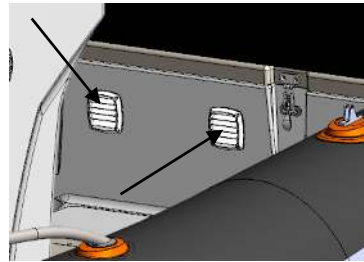

Fig. 7. Ventilation openings on the rear dry storage compartment.

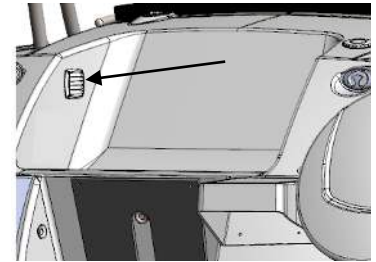

Fig. 8. Ventilation opening on the left side of transom area.



DANGER

DO NOT OBSTRUCT OR MODIFY THE VENTILATION SYSTEM AND VENTILATION OPENINGS.
KEEP VENTILATION OPENINGS UNOBSTRUCTED AT ALL TIMES.



BEFORE FUELING

- Check the engine manufacturer's manual for information about the correct type of fuel be used for proper and long-term trouble-free operation.
- Turn off the engine.
- Turn off the ignition.
- Be sure to extinguish any open flames.

CAUTION

USING POOR QUALITY OR UNSUITABLE FUEL CAN RESULT IN DAMAGE TO YOUR ENGINE!
IT IS PREFERABLE NOT TO STORE UNUSED FUEL FOR LONG PERIODS IN THE FUEL TANK AND FUEL SYSTEM AS THIS CAN RESULT IN DAMAGE TO FUEL LINES, PUMPS AND FILTERS.

EXPLOSIVE/FIRE HAZARD

DANGER

IF A FUEL LEAK OR FUMES ARE DETECTED, DO NOT START THE ENGINE. ENSURE ALL CREW LEAVE THE BOAT AND HAVE A QUALIFIED PERSON REPAIR THE DEFECT AS SOON AS POSSIBLE. NEVER USE A FLAME TO CHECK FOR LEAKS.



SAFETY



WARNING

CHECK FOR FUEL AND GAS VAPOURS OR FUEL LEAKS AT REGULAR INTERVALS AND BEFORE STARTING THE ENGINE.

HOSES SHOULD BE INSPECTED AT LEAST ANNUALLY AND REPLACED IF ANY DETERIORATION OR DAMAGE IS FOUND. IF FUEL LEAKAGE IS PRESENT, HAVE THE SYSTEM REPAIRED BEFORE FURTHER USE. FUEL SYSTEM REPAIRS SHOULD ONLY BE MADE BY COMPETENT PERSONNEL.

WHILE FUELING

- Keep hose nozzle in contact with the filler pipe to provide a ground against static sparks.
- Fill the tank slowly to avoid danger of spillage.
- Do not overfill the tank. Leave some room for the fuel to expand. In hot conditions fill the tank to about 80% of its maximum capacity.

If fuel is spilt on the hull, use an ordinary, non-abrasive cleaner then wipe with a damp cloth and rinse the area with clean water.



WARNING

NEVER FILL ANY FUEL TANK WHEN ENGINE IS RUNNING.



FIRE-FIGHTING EQUIPMENT

Most fires are caused by electrical problems or careless fueling.

In case of fire, we recommend to stop the motor and turn off the battery switch.

It is the owner/helmsman's responsibility to have appropriate fire extinguishers in serviceable condition and readily accessible on board as prescribed by local requirements. At least one portable extinguisher type 34 B shall be present on board. The storage compartment of a portable fire extinguisher is marked by the symbol shown in fig. 9.



Fig. 9. Symbol of designated place of portable fire extinguisher.

This boat, when in service, shall be equipped with portable fire extinguisher of the following extinguishing capacities and in the following recommended location:

Nº1 Location: Bow locker Fire rating: 34B



WARNING

NEVER OBSTRUCT ACCESS TO PORTABLE EXTINGUISHER.



SAFETY



WARNING

NEVER EXTINGUISH BURNING FUEL OR ELECTRICAL WIRING WITH WATER!

IF THE FIRE IS SMALL, TRY TO PUT IT OUT WITH A FIRE EXTINGUISHER OR BY THROWING A FIRE BLANKET OVER THE FLAMES.

IF THE FIRE OCCURS IN THE FUEL SYSTEM AND GETS OUT OF CONTROL AND CALL FOR HELP.

BEFORE ALL PASSENGERS ARE FORCED TO LEAVE THE BOAT, CHECK THAT EVERYONE IS WEARING A LIFEJACKET.

DUE TO THE FACT THAT BURNING FUEL MAY SPREAD OVER THE SURFACE OF THE WATER AND THE RISK OF EXPLOSION, TRY TO SWIM A SAFE DISTANCE AWAY FROM THE BOAT.



ELECTRICAL SYSTEMS - SAFETY RULES

- Check condition of battery and charging system before departure.
- When the electrical system is in use check that individual components are working satisfactorily.
- Disconnect and remove the battery when the craft is in winter storage (cold weather areas) or long-term storage.

WARNING

NEVER WORK ON THE ELECTRICAL INSTALLATION WHILE THE SYSTEM IS ENERGIZED.

NEVER MODIFY THE CRAFT'S ELECTRICAL SYSTEM; INSTALLATION AND MAINTENANCE SHOULD ONLY BE PERFORMED BY A QUALIFIED MARINE ELECTRICAL TECHNICIAN.

NEVER ALTER OR MODIFY THE RATED CURRENT AMPERAGE OF OVERCURRENT PROTECTIVE DEVICES.

NEVER INSTALL OR REPLACE ELECTRICAL APPLIANCES OR DEVICES WITH COMPONENTS WHICH EXCEED THE RATED CURRENT AMPERAGE OF THE CIRCUIT.

NEVER LEAVE THE CRAFT UNATTENDED WITH THE ELECTRICAL SYSTEM ENERGIZED, EXCEPT AUTOMATIC BILGE PUMP, FIRE PROTECTION AND ALARM CIRCUITS.



SAFETY

BATTERY

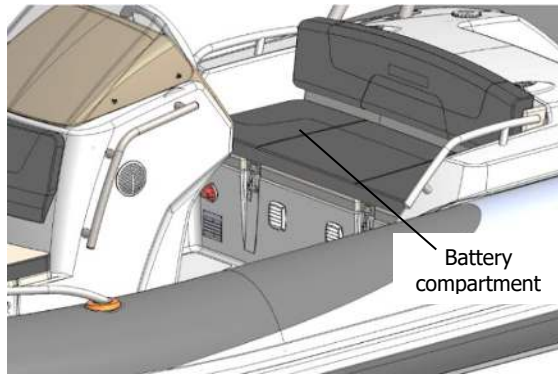

Fig. 10. battery location.

IMPORTANT NOTICE Don't forget to switch off the battery isolator switch if you no longer intend to use the boat.



1. AVOID SPARKS AND EXPOSED FLAMES NEAR BATTERY. IT MAY EXPLODE.
2. TURN OFF THE ENGINE WHEN INSPECTING OR SERVICING THE BATTERY.
3. NEVER KEEP THE BATTERY CLOSE TO A FUEL TANK, FILLER OR FUEL SYSTEM COMPONENTS.

If you don't use the boat/battery for long time or during winter period, recharge the battery at least one a month to extend the battery life.

If an unsealed battery is used, take care to check periodically the electrolyte level.

Specific information about battery care could be found in its manual.



MAN-OVERBOARD PREVENTION AND RECOVERY

Man-overboard prevention.

The working deck has an anti slip surface.

When the boat is underway, the helmsman and passengers should always occupy designated seating areas, using handles when necessary. Other parts such as seat backs, cleats, windscreen tops and rails can be used as handholds to reduce the risk of falling overboard.



WARNING

IF PASSENGERS ARE NOT IN DESIGNATED SEATING WHEN UNDERWAY THERE IS A RISK OF FALLING INSIDE THE BOAT OR OVERBOARD CAUSING SERIOUS INJURY OR DEATH.

DO NOT MAKE SHARP TURNS AT HIGH SPEEDS: YOU COULD BE EJECTED FROM THE BOAT.

DO NOT MAKE VIOLENT CHANGES IN DIRECTION WITHOUT INFORMING PASSENGERS.

Areas such as the bow step plate, the engine well, tube step ends should not be used as seating when the boat is underway.



MEANS OF REBOARDING

This boat is equipped with a rigid foldable ladder (fig. 11), which allows a person to reboard easily without any assistance. Additional handle for assistance while re-boarding is located close to the ladder.

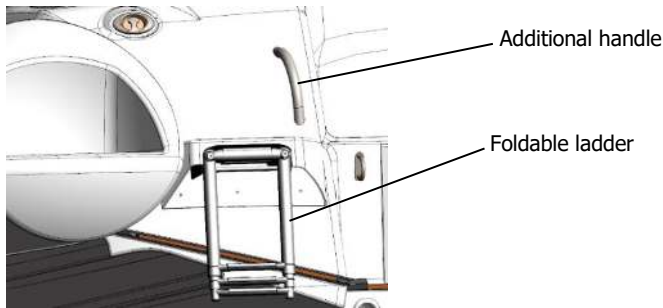

Fig. 11. Foldable ladder and handle for assistance with re-boarding.

DANGER FROM MOVING PARTS



DO NOT USE SWIMMING PLATFORMS WHEN ENGINE IS RUNNING!

KEEP AWAY FROM MOVING PROPELLER! IT COULD RESULT IN INJURY OR DEATH!

Even in neutral, engine's propeller may rotate and may cause injury. If a person is in the water near the boat, immediately switch off the engine to avoid injury from the propeller rotation.



SAFETY EQUIPMENT

The owner/helmsman is responsible for ensuring that appropriate safety equipment is onboard and is in proper working condition. The type of safety equipment and quantity will depend on the conditions expected and length of trip.

The type of safety equipment required will depend on local or national regulations. In most countries, safety equipment of the following type is required:

- Emergency Engine Kill Switch Lanyard.
- Personal Flotation Devices (PFD).
- Fire extinguisher.
- Horn or Whistle.
- Bilge pump (s).
- Visual Distress Signals.



CONSULT YOUR LOCAL DEALER REGARDING REQUIRED SAFETY EQUIPMENT IN YOUR COUNTRY/STATE BEFORE GOING AFLOAT.

Planning a trip, remember that not all fuel can be used from the fuel tank depending on the load and trim. About 20% can remain in the fuel tank.



SAFETY

In addition to the required safety equipment, we recommend tools as listed below. You can also ask your Dealer for any additional recommendations or advice based on local requirements.

RECOMMENDED EQUIPMENT

- An anchor with at least 25 meters of line.
- A manual bailing device for removing water from the boat (bucket, hand pump).
- A combination oar/boat hook.
- A day-and-night visual distress signal.
- A first aid kit and manual.
- An airway breathing tube.
- A waterproof flashlight.
- A set of local navigation charts.
- A whistle or non-electric horn.
- Mooring lines and fenders.
- Extra engine oil.
- A tool kit.
- A portable AM/FM radio or weather radio.
- Cell Phone with waterproof container.
- Binoculars.



SAFETY DRIVING RULES

WARNING

- DO NOT USE ALCOHOL/DRUGS BEFORE OR WHILE OPERATING YOUR BOAT.
- AVOID BOW RIDING AS IT MAY BE ILLEGAL AND IS EXTREMELY DANGEROUS.
- KEEP CLEAR OF SWIMMERS AND DIVERS: ALWAYS AVOID AREAS WHERE DIVERS/SWIMMERS ARE PRESENT.
- KEEP A SHARP LOOKOUT ESPECIALLY WHEN OPERATING NEAR BEACHES AND BRIDGES.
- SHUT OFF THE MOTOR WHEN OPERATING NEAR SOMEONE IN THE WATER. THE INTERNATIONAL CODE FLAG ALPHA INDICATES PROXIMITY OF DIVERS. MAINTAIN A SAFE DISTANCE (MINIMUM 50 METERS) AT ALL TIMES.
- A HELMSMAN OR A PERSON WHO KNOWS HOW TO STEER THE BOAT SHOULD ALWAYS REMAIN ON BOARD WHILE THE PASSENGERS ARE IN THE WATER EVEN IF THE BOAT IS ANCHORED.

CAUTION

THE OWNER IS RESPONSIBLE FOR ENSURING THAT THE NORMAL MODE OF OPERATION IS MAINTAINED. THIS MEANS THAT THE SPEED OF THE CRAFT NEEDS TO BE MATCHED TO THE PREVAILING SEA STATE, THE CRAFT BEING USED "WITH GOOD SEAMANSHIP BEHAVIOUR".



SAFETY

WARNING

More the speed is higher, more risks are involved.

If you are not an experienced driver, we recommend not to exceed 30 knots.

Be realistic about your capabilities.



THE BOAT IS DESIGNED FOR RECREATIONAL PURPOSES ONLY, NOT FOR COMPETITIONS.

Please remember also that the is not designed to jump through the waves. The builder is not responsible for any damage from excessive loads resulting in neglect of the precautions outlined in this manual.



SAFETY LABELS

 CAUTION	
<ol style="list-style-type: none"> 1. You must read the User's Manual of your boat and follow all the instructions. 2. You have to know all the state and local boating laws and follow all their requirements. 3. You must wear the life jacket or other approved personal flotation device when boating. 4. Always use the Stop Switch Lanyard of your engine. 5. No drinking alcohol or taking drugs before or while operating the boat. 6. Do not exceed max number of persons, loading or engine power/weight authorized. 7. Make sure your passengers remain seated on seats (not on tubes) when boating. 8. Keep clear of swimmers & divers. Shut the engine off if someone is nearby in the water. 9. No sharp turns or sudden changes in direction without warning of passengers. 10. Keep the boat, engine, steering, electric & fuel systems clean and well maintained. 	

 CAUTION	
	<p>TUBE SHOULD ALWAYS HAVE CORRECT WORKING PRESSURE WHEN BOAT IS IN USE.</p> <p>CORRECT PRESSURE IS 0,15 BAR / 2,15 PSI.</p>
	<p>FAILURE TO KEEP CORRECT PRESSURE WILL AFFECT THE PERFORMANCE OF THE BOAT AND CAN BE DANGEROUS!</p> <p>WRONG PRESSURE WILL SHORTEN TUBE LIFE AND RESULT IN PERMANENT DAMAGE TO BOAT!</p>

WARNING!	
YES!	NO!
<p>INSTRUCTIONS</p> 	<p>Alcohol</p> 
	
	



SAFETY



WARNING



DO NOT OVERLOAD TOWING MAST/ARCH.
THE MAST/ARCH IS DESIGNED FOR
TOWING 1 (ONE) PERSON
(NOT MORE THAN 120 KG / 265 LBS).
DO NOT USE MAST/ARCH TO PULL A TUBE.
TOW ROPE MAY BACKLASH INTO COCPIT.



CAUTION



USE A BIMINI TOP WHEN
YOUR BOAT IS NOT IN MOTION.
COLLAPSE BIMINI TOP IN STOWED POSITION
IF YOU ARE PLANNING TO CRUISE AT MORE
THAN 20-25 KNOTS.



WARNING



ALWAYS STORE REMOVABLE TABLE INSIDE
THE STORAGE COMPARTMENT
IF YOU ARE PLANNING TO CRUISE
AT MORE THAN 15 KNOTS.



CAUTION



ALWAYS STORE REMOVABLE SUNDECK
INSIDE THE STORAGE COMPARTMENT
IF YOU ARE PLANNING TO CRUISE
AT MORE THAN 15 KNOTS.



2. BOAT IDENTIFICATION

BOAT'S IDENTIFICATION NUMBER

Every boat has “Watercraft Identification Number” (WIN), which uniquely identifies your boat and is important for safety and identification purposes. The WIN is marked on a non-removable metal plate, which is fixed to the transom area of your boat (fig. 12).

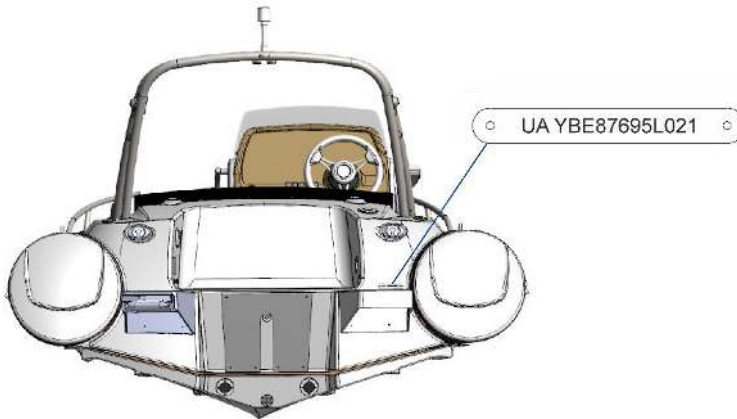

Fig. 12. Location of the WIN plate.



BOAT IDENTIFICATION

BUILDER'S PLATE

The builder's plate (fig. 13), which is fixed to the craft, provides information about the Manufacturer including manufacturer's name, registered trade or trade mark plus contact name and address, CE marking, craft design category, maximum recommended load minus liquids in fixed tanks, number of persons recommended by the manufacturer for which the craft was designed. This information may not however comprise a complete list: safety requirements (obligatory safety equipment carried on the boat, maximum authorized distance you can navigate from a port, etc.) may vary according to the country or state.

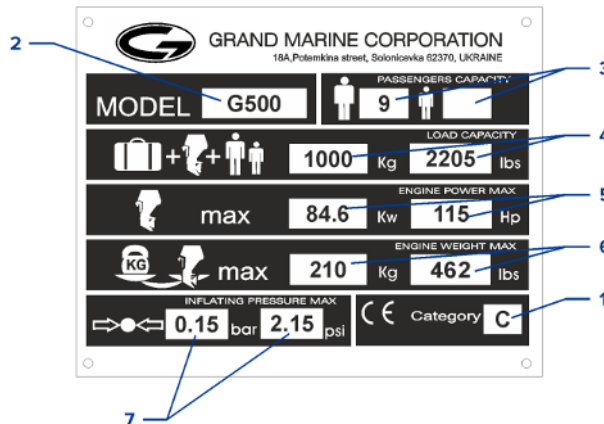

Fig. 13. Builder's plate.

1 - Design category*

2 - MODEL: Catalogue name or model number.

3 - Maximum number of people authorized on board (adults + children) according to ISO standards.

4 - Maximum load capacity of the boat allowed by the manufacturer and expressed in kilograms and lbs.

5 - Maximum outboard power allowed by the builder for the boat and expressed in kilowatts and HP.

6 - Maximum weight of outboard motor allowed by the manufacturer expressed in kilograms and lbs.

7 - Nominal Pressure of the buoyancy tubes in Bar and Psi.



Always refer to local regulations for information on additional requirements.

*Design category (European Directive 2013/53/EU):

Category	C	D
Navigation	"Inshore"	"Protected water"
Wind speed (Beaufort scale)	Up to and including F6	Up to and including F4
Significant height of wave to consider (in meters)	Up to and including 2m	Up to and including 0.3m



BE RESPONSIBLE, TAKE NOTE AND DO NOT NAVIGATE IF THE CONDITIONS ARE LIKELY TO EXCEED THESE PARAMETERS.



BOAT IDENTIFICATION

LOCATION OF THE BUILDER'S PLATE

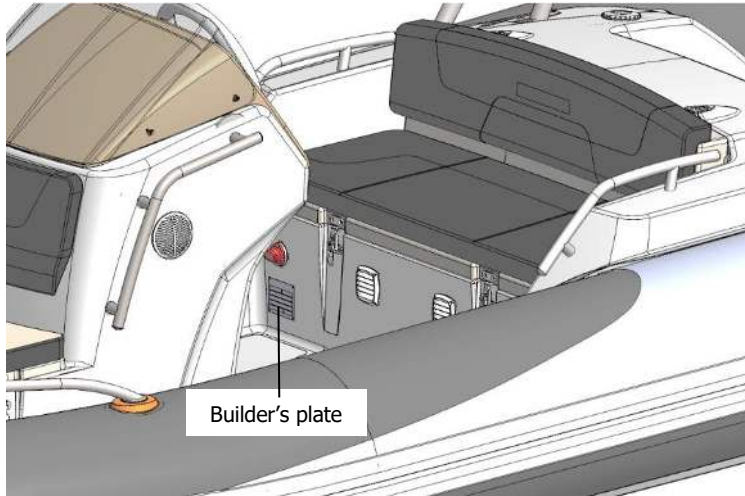

Fig. 14. Location of the Builder's plate.



3. BEFORE OPERATING YOUR CRAFT

CHECKLIST BEFORE DEPARTURE

- Using a pressure gauge (not supplied), check inflation pressure in each section of the tube.
- Check the tightness of the outboard motor clamps or bolts.
- Inspect the steering system: an improperly maintained system may fail, causing sudden loss of control.
- Remove the cockpit and hull drain plugs, check the gaskets, replace if necessary.
- Check the fuel system.
- Top off fuel and lubricating oil levels to required levels. Note: do not overfill fuel tank.
- Be sure that you do not exceed the recommended maximum load indicated on the Builder's plate. Check the load is evenly distributed.
- Make sure that each passenger is seated or has a seat available. Inform all passengers regarding the necessity to hold on to safety handles. Check that each passenger has his personal flotation device.
- Check that all required safety equipment is on board (horn, first aid kit, waterproof light, cell phone in watertight case, fresh water reserve etc.).
- Check that the boat is equipped with an additional flotation device for emergency use.
- Check that the boat is equipped with two oars/paddles. Check the condition of the oars and rowlocks.
- Be sure that the boat is equipped with at minimum 2 x boat length of suitable towing line.



BEFORE OPERATING YOUR CRAFT

WEATHER

Before starting any trip, check the local weather forecast. Depending on location and seasonal conditions, the weather can sometimes change very quickly. If the weather suddenly changes and conditions become rough:

- Try to find shelter as soon as possible because riding out a storm at sea can be extremely dangerous.
- Reduce speed whilst maintaining sufficient power to continue making headway.

GENERAL

1. OBTAIN INFORMATION on local regulations and hazards related to marine activities and boat operation.
2. ADVISE someone on land when you expect to be back.
3. EXPLAIN basic boat operation to all passengers.
4. ENSURE that at least one passenger is able to operate the craft and motor, provide training as needed.
5. FAMILIARISE all passengers with safety procedures and drills.
6. LEARN how to estimate the distance you can cover with a full tank of fuel. Always be sure you have enough fuel to reach your destination or a place of safety.
7. CHECK you have all necessary documentation and licenses.



RULES TO OBSERVE WHEN AFLOAT

- Be responsible: do not ignore safety rules.
- Make sure that you are always in control of your boat.
- Always operate your boat with courtesy and respect for others.
- Respect local regulations and practices.
- Near the shore, navigate within designated boating areas.
- Always be sure that you can reach shelter quickly.



OPERATING THE CRAFT

4. OPERATING THE CRAFT

TUBE INFLATATION

Inflation valve.

A boat is equipped with a valve as shown in figure 15.

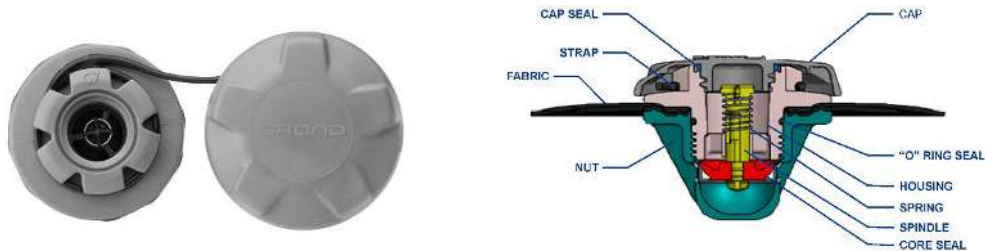
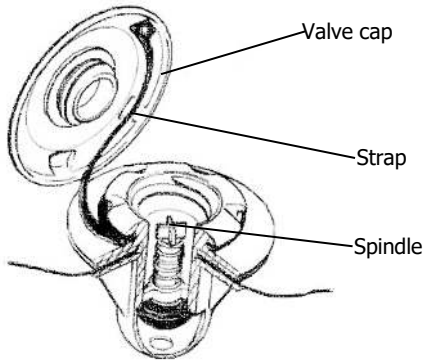

Fig. 15. Inflation valve.

To inflate the tube chamber, first open the valve cap by turning it about half a turn counter clockwise (fig. 16). The spindle should be in the upper (closed) position.

“O” ring and cap seals of the valve can wear out overtime and can be subject to change.



a) The valve is closed



b) The valve is open

Fig. 16. Design of the inflation valve.

When the spindle is in the normal (closed) position, the valve operates as a check valve and opens when air is pumped into the tube.

To release air from the tube, press down and hold the spindle. If you need to fully deflate the tube, press and turn the spindle counter clockwise to lock it in the "open" position.

In order to quickly and completely deflate the tube we recommend to use a supplied pump.



OPERATING THE CRAFT

To inflate the tube chambers, use the foot pump (fig. 17) supplied.



Fig. 17. Foot pump

Insert the end of the hose into the inflation valve using one of the appropriate adapters.

Make sure the adaptor makes an air-tight connection with the valve and inflate using foot pump.

To inflate the tube, you can also use a small electric boat pump.

CAUTION

IF YOU USE A SMALL ELECTRIC PUMP, COMPLETE THE PROCEDURE BY USING THE FOOT PUMP TO REACH THE REQUIRED NOMINAL PRESSURE.



Begin the inflation procedure according to the sequence shown in figure 18. Initially, partially inflate each chamber (approx. 0.1 bar (1.45 psi)) then repeat the procedure inflating each chamber to its nominal pressure, 0.15 bar (2.15 psi).

The nominal pressure is 0,15 bar (2,15 psi).

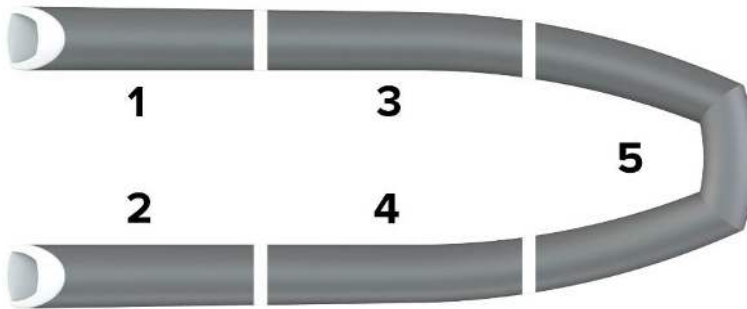

The drop of pressure up to 20 mbar is normal after the boat has been put on the water due to the difference between air and water temperature.

Fig. 18. Tube inflation sequence.

Check the pressure in each chamber with a pressure gauge. If you do not have a pressure gauge the following procedure will serve as a guide. Press a finger firmly against the tube – if the tube is depressed by about 10 mm ($\frac{3}{8}$ inch) this indicates that the pressure is approximately correct.

After the tube chambers have been inflated to the nominal pressure place the valve caps back.



OPERATING THE CRAFT

Valve caps protect the valves from accidental opening, provide a secondary seal and protect the valves from contamination.

The valves require little maintenance. Keep them clean using a standard household cleaner.

Remember that changes in ambient temperature will change the inflation pressure within the tube *especially in tropic areas*. If there is no overpressure valve, a tube that was inflated to or above its nominal pressure in the morning can be loaded beyond its design pressure and be damaged by a significant pressure increase resulting from the thermal expansion of the gasses due to increase in temperature in the afternoon.



WARNING

IF THE PRESSURE WITHIN THE TUBE BECOMES EXCESSIVE, THE GLUED SEAMS MAY BE DAMAGED.

If the ambient temperature rises significantly or you intend leaving the boat in direct sunlight, we recommend you relieve the air pressure in each chamber. It is strongly recommended that the boat be kept in the shade or under cover when not in use.



CAUTION

DO NOT USE SOURCES OF HIGH-PRESSURE COMPRESSED AIR FOR INFLATING THE TUBE. EXCESSIVE PRESSURE CAN DAMAGE THE GLUED SEAMS AND THE INTERNAL WALLS.



OVERPRESSURE VALVE (IF FITTED)

Overpressure valves can be fitted to buoyancy tubes as shown in figure 19.

It serves to protect the tube from over inflation and excess pressure build up due to solar heat.



Without strainer



With filter cap

Fig. 19. Overpressure valve.

Ultrafine mesh of the filter cup prevents contamination without affecting the pressure relief function. The filter cap can be easily removed for cleaning.



OPERATING THE CRAFT

MOTOR INSTALLATION

Information about motor trim is given for reference purposes only.



Please refer to the manual supplied by motor manufacturer before operating the motor and craft.

The engine manufacturer's dealer or authorized agent should undertake installation of the motor on your boat.

The optimum position is with the propeller axis parallel with the water.

CORRECT



Fig. 20. Optimum trim.



If the motor is tilted too far outwards from the transom, the boat will tend to porpoise.

INCORRECT



Fig. 21. Trim up.

If the motor is tilted too far inwards towards the transom the boat will travel bow down.

INCORRECT



Fig. 22. Trim down.



OPERATING THE CRAFT

MOTOR START&STOP

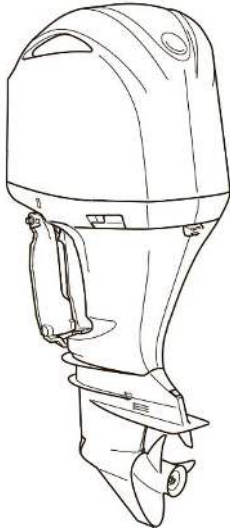

Fig. 23. Motor.

CAUTION

BE SURE THE MOTOR IS NOT IN GEAR BEFORE ATTEMPTING TO START IT!

CAUTION

ALL EQUIPMENT THAT BURNS FUEL WILL REQUIRE AN AIR SUPPLY. ENSURE ALL AIR INTAKES ARE CLEAR BEFORE FUEL-BURNING EQUIPMENT IS USED.

Routine maintenance should be carried out in strict conformity with the instructions given in the appropriate motor owner's manual.





ENGINE KILL SWITCH LANYARD

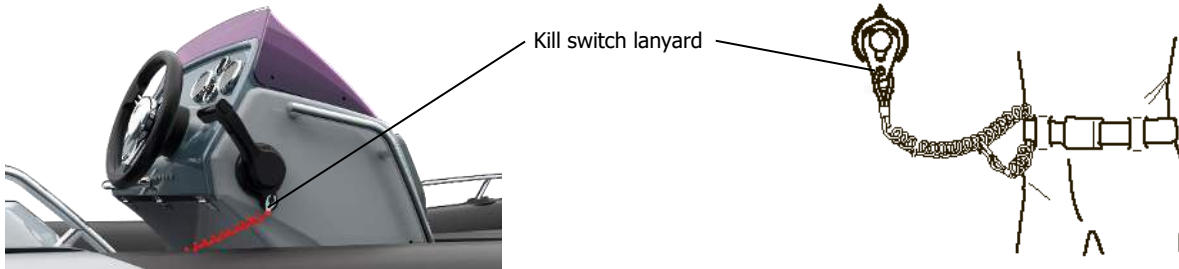

Fig. 24. Engine kill switch lanyard.

For safety reasons always use the engine kill switch lanyard.

The purpose of the engine kill switch lanyard is to turn off the engine if for any reason the helmsman is removed from the steering position.

The kill switch is located next to the ignition key.



DANGER

WHEN THE ENGINE IS RUNNING, THE KILL SWITCH LANYARD SHOULD ALWAYS BE WORN ON THE WRIST, ANKLE, OR FIXED TO YOUR CLOTHES OR TO YOUR PERSONAL FLOTATION DEVICE. IGNORING THIS INSTRUCTION MAY CAUSE DEATH OR SERIOUS INJURY.



OPERATING THE CRAFT

ELECTRICS

System voltage – 12V, two-wire d.c. system with negative ground (earth). Connection is done through a motor.

BATTERY ISOLATOR SWITCH

The battery isolator switch is designed to isolate the battery from the boat's electrical circuit. It is used when the boat is in long-term storage to prevent the battery becoming drained, during maintenance (this should be done by qualified electrical technician) and in emergency cases.

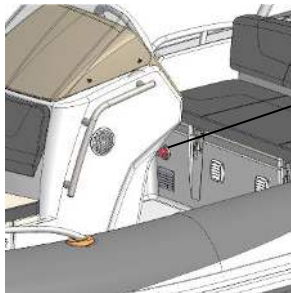

Battery isolator switch

Specification:

Operating voltage: up to 48 Volt DC.

Max. current: 450 A - 5 min, 700 A - 10 sec.

The battery isolator switch is located on the external/internal; side of the rear compartment in an accessible place for the helmsman. It should be accessible at all times for disconnecting all devices from the battery.

Fig. 25. Battery isolator switch.



CAUTION

THE BATTERY MUST NEVER BE DISCONNECTED FROM THE ENGINE WHEN IT IS RUNNING!



SWITCH PANEL

Use the following switches located on the steering console to switch on/off a horn, navigation lights, anchor/all-round light, bilge pump and shower.

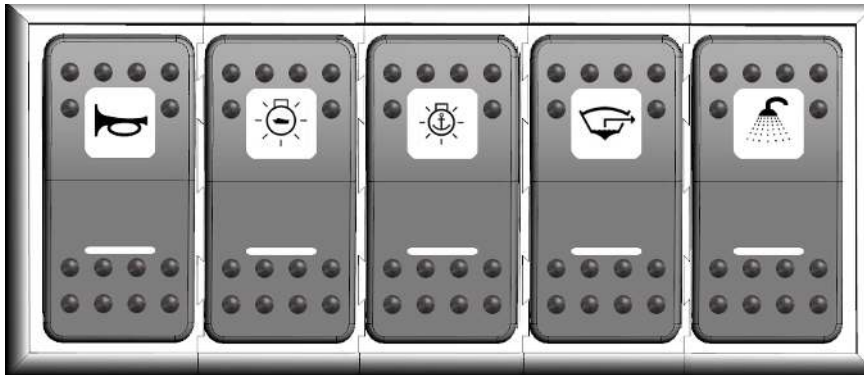

Horn

Navigation
lights

Anchor/all
round
light

Bilge pump

Shower



Fig. 26. Switch panel.



OPERATING THE CRAFT

BLADE FUSE BOX

The fuse box is located on the right inboard side of steering console (under the seat).

To change a fuse, unlock and open fuse box transparent cover. Pull out a blown fuse and replace it with a new one. Place the fuse box cover back.

A rating of relevant fuses is given below.

IMPORTANT NOTICE Be sure to always have a spare set of appropriate fuses on board.

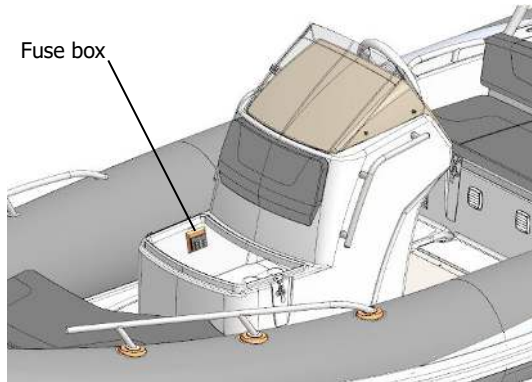

Circuit	Fuse rating, A
Horn	5
Navigation lights	5
Anchor/All-round light	5
Bilge pump	4
Shower pump	5
Accessory socket	2

Fig. 27. Location of the fuse box.



ELECTRICAL HORN

The horn serves as a warning to other craft and individuals when setting off, mooring or in other safety related situations.

The horn is mounted on the steering console.

The horn is switched on/off by means of a switch located on the steering console. To use the horn press and hold the switch. Release the switch to turn the horn off.

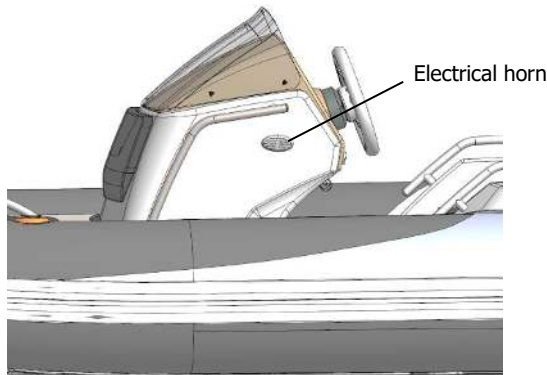

Fig. 28. Electrical horn.

Before making a trip, check the horn is functioning by briefly switching it on/off.



OPERATING THE CRAFT

NAVIGATION LIGHTS

Navigation lights are designed to indicate the craft's relative position, the nature of its movement or its location at night. The side lights are a green light on the starboard side and a red light on the port side.

Navigation lights are located on the arch/bow step plate (side lights) and on the arch (all-round) light.

Use the switch on the steering console to turn the navigation lights on/off when needed.

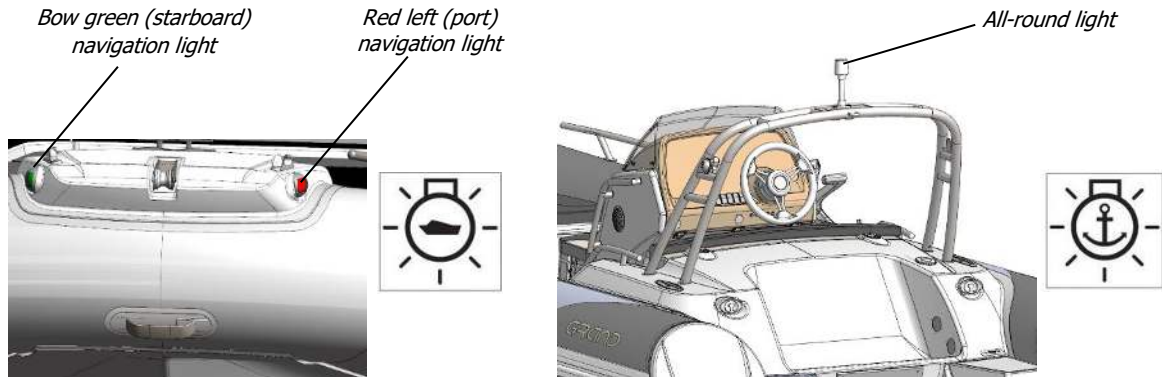

Fig. 29. Navigation lights.



LIFTING EYES

To lift the boat and place it on davits, use the factory fitted lifting eyes only (figs. 30, 31). The lifting eyes are designed to withstand the full weight of the boat with max motor. Use only the appropriate certified lifting slings that are capable of handling such a load.

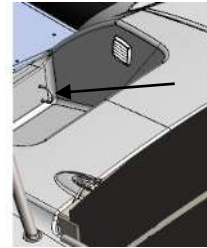
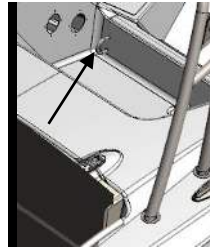
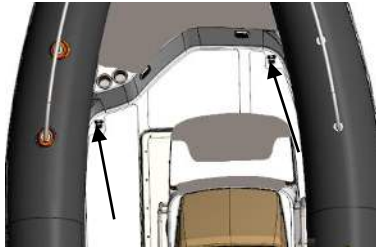

Fig. 30. Bow lifting eyes, 2 positions.

Fig. 31. Rear lifting eyes, 2 positions.

Before lifting the boat:

- make sure that the boat is completely empty when being lifted; it means remove any items that could fall out of the boat during the lifting process, such as luggage, gear, and other loose objects.
- open the cockpit drain plugs to allow water (such as rainwater) to drain out easily.

When the boat is on land, a davit, or a trailer, open the hull drain plug to ensure water can drain out of the boat.



WARNING

MAKE SURE NOBODY IS ON BOARD WHEN LIFTING.



OPERATING THE CRAFT

COMPONENTS OF A BOAT

BOW ANCHOR STORAGE/BOW LOCKER

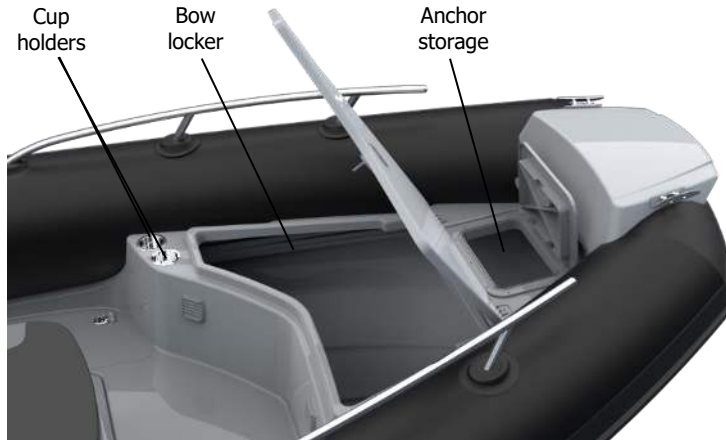

We recommend to have all lockers, storage boxes, hatched compartments are closed securely.

Fig. 32. Bow locker with large access cover and soft cushion.



CAUTION

BE CAREFUL WHEN OPENING/CLOSING THE HATCHES. THEIR ACCIDENTAL CLOSING COULD INJURE YOU.



REAR LOCKER WITH SOFT SEAT AND SEAT BACK

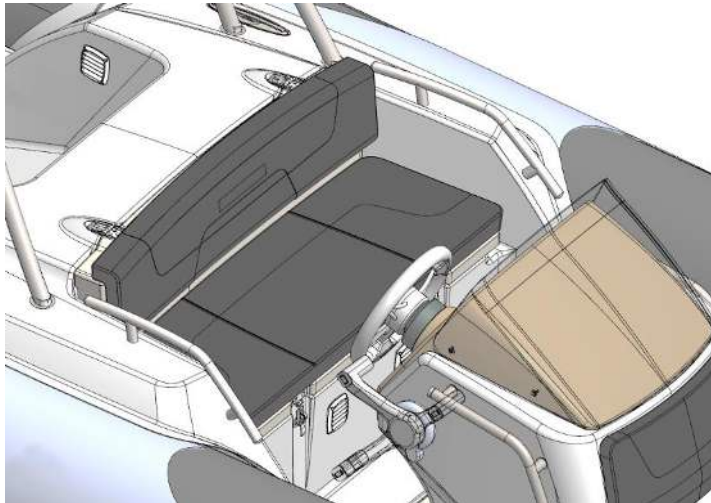

IMPORTANT NOTICE

Before make a trip, check that all cushions are fastened well.

Always remove the cushions carefully.

Do not pull the cushion to open a snap button.

Fig. 33. Rear locker with access panel, lifters, soft seat and seat back.



OPERATING THE CRAFT

REMOVABLE BOW SUNDECK WITH CUSHION (IF APPLICABLE)

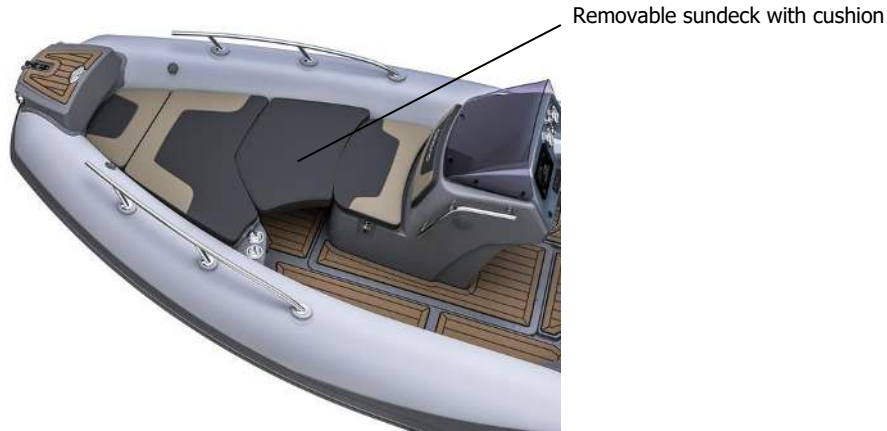

Fig. 34. Removable sundeck with cushion.



WARNING

NEVER USE BOW SUNDECK WHEN THE BOAT IS UNDERWAY. THERE IS A RISK TO FALL OVERBOARD.



CAUTION

ALWAYS STORE REMOVABLE SUNDECK INSIDE THE STORAGE COMPARTMENT IF YOU ARE PLANNING TO CRUISE AT MORE THAN 15 KNOTS.



REMOVABLE BOW SUNDECK EXTENSION WITH CUSHION (IF APPLICABLE)



Fig. 35. Removable sundeck extension with cushion.

CAUTION

ALWAYS STORE REMOVABLE SUNDECK EXTENSION INSIDE THE STORAGE COMPARTMENT IF YOU ARE PLANNING TO CRUISE AT MORE THAN 15 KNOTS.



OPERATING THE CRAFT

STAINLESS STEEL RAILS (IF APPLICABLE)

Stainless steel bow rails

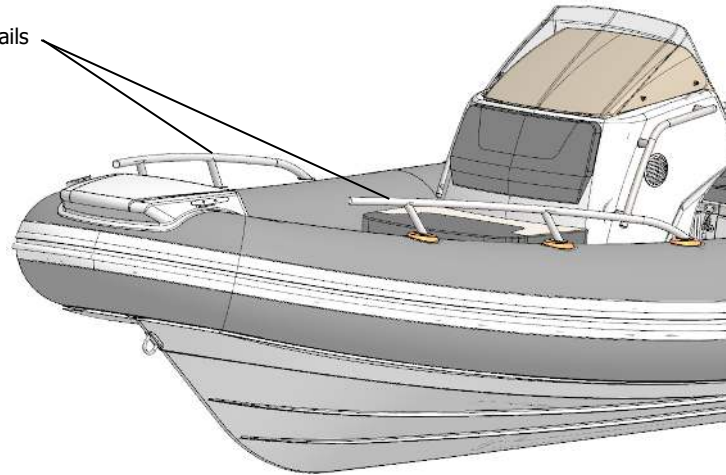

Fig. 36. Stainless steel bow rails.



CAUTION

NEVER USE THE RAILS FOR MOORING. TIE-UP ONLY TO THE CLEATS AND BOW TOWING EYE



COLLAPSIBLE BIMINI TOP (IF APPLICABLE)



Fig. 37. Collapsible bimini top.

CAUTION

USE A BIMINI TOP WHEN YOUR BOAT IS NOT IN MOTION. KEEP BIMINI TOP IN STOWED POSITION IF YOU PLANNING TO CRUISE AT MORE THAN 20-25 KNOTS.

STORE THE BIMINI TOP IN FOLDED CONDITION IF YOU ARE NOT GOING TO USE IT FOR A LONG TIME.



OPERATING THE CRAFT

BIMINI TOP INSTALLATION PROCEDURE

A Bimini top is supplied pre-assembled.

1. Unpack the Bimini Top.
2. Unfold it, then insert the poles into connectors (fig. 38).



Fig. 38. Close view of connectors.

3. Insert the pole eye end into support, securing by a thumb screw.
4. The same procedure should be repeated on the opposite side.
5. Open a top canvas.
6. Fix the adjustable straps to the attachment structures located on the bow and the stern.
7. Check that the top canvas is well stretched and all fastenings are tightened.



SWIMMING PLATFORM (S) WITH FOLDING LADDER

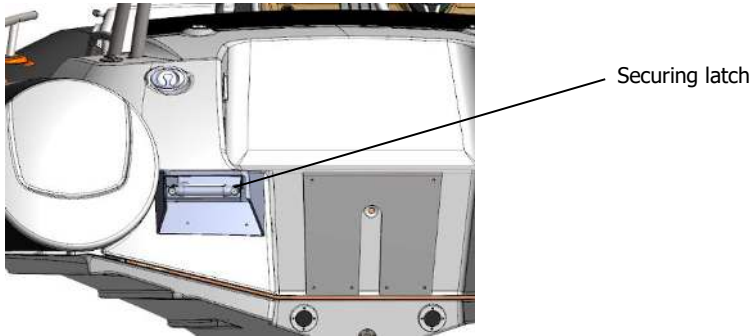

Fig. 39. Swimming platform with folding ladder.

CAUTION

CHECK THAT THE FOLD DOWN SECURING LATCH IS IN PLACE BEFORE BEGINNING A TRIP OR TRAILERING THE BOAT.

THE JOINTS OF TELESCOPIC LADDER CAN INJURE YOUR HANDS. PLEASE BE CAREFUL.

WARNING

DO NOT USE SWIMMING PLATFORMS WHEN ENGINE IS RUNNING!



OPERATING THE CRAFT

WATER SHOWER SET (IF APPLICABLE)

A pump and 50-liter tank available.

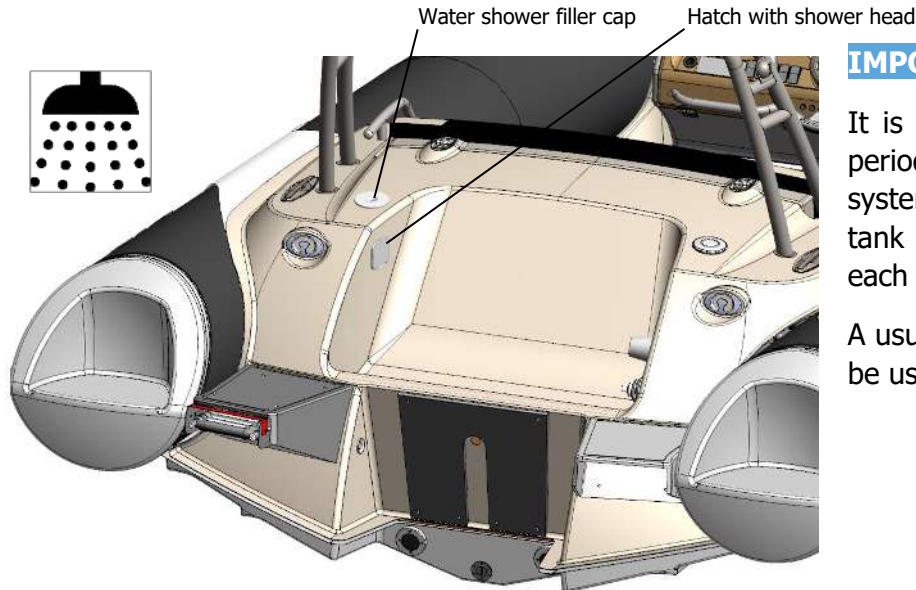

IMPORTANT NOTICE

It is a good practice to rinse periodically the water supply system and fill up the water tank with freshwater after each use.

A usual household cleaner can be used for system cleaning.

Fig. 40. Water shower set.



WATERSKI TOWING ARCH (IF APPLICABLE)

Always observe safe driving procedures when towing a water skier.

For information about waterski towing procedures contact your local power boat school or yacht club.

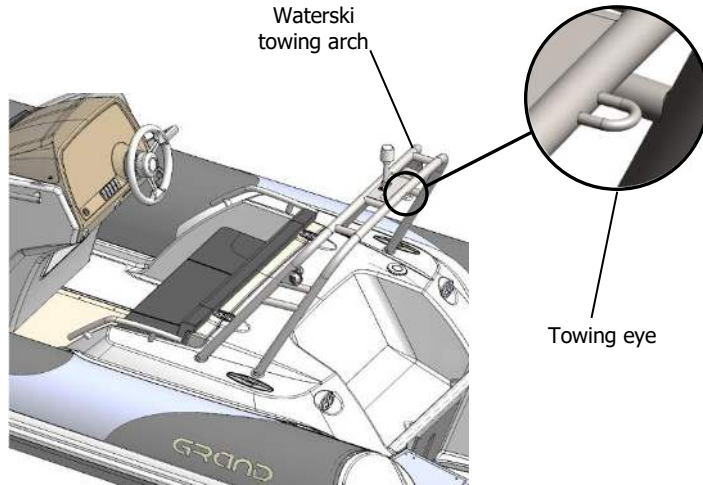

WARNING

THE SAFE WORKING LOAD OF THE TOWING MAST IS INDICATED ON A LABEL ATTACHED TO THE ARCH.

NEVER ALLOW PASSENGERS TO SIT ON REAR SEAT BACK WHEN TOWING A SKIER. SHOULD THE TOWROPE PART IT COULD BACKLASH INTO THE COCKPIT.

DO NOT USE THE TOWING ARCH TO PULL ANY KIND OF TUBING (BANANA TUBE, DONUT, TUBE BUMPER, KITE TUBE, INFLATABLE TORUS, BISCUITING ETC.).

Fig. 41. Waterski towing arch.



OPERATING THE CRAFT

SEADECK ANTISKID SET (IF APPLICABLE)



Fig. 42. SeaDeck antiskid product.

Safe and comfortable non-absorbent long-life product specially designed for marine application. Textured micro-dot robust surface ensures:

- Exceptional traction even when wet.
- Unparalleled comfort when standing, walking or leaning on boat surfaces.
- Shock absorption, which decreases fatigue.
- Protection for boat surfaces against scratches, chips and dents.
- Noise reduction characteristics – ideal for fishermen.

The following area of your boat (depending on the model) can be enhanced by SeaDeck antiskid material:

- Deck
- Bow step plate
- Swimming platforms
- Fiberglass step ends

Extremely stain resistant SeaDeck surface, if needed, can be easily cleaned with soap, hot water, and a stiff brush. For best cleaning results tend to remove all stains, spills and leaks as soon as possible.



DO NOT USE ACID-BASED CLEANERS. AVOID TO USE HIGH PRESSURE WASHERS.



ANCHORING, MOORING AND TOWING

ANCHORING

Please make sure your craft is equipped with an appropriate anchor and line. If you are not sure, ask your Dealer who will be happy to advise. Setting-up a securing anchorage requires knowledge and practice so it is important that properly trained persons undertake this procedure.

When anchoring your boat make sure you are not creating a potentially dangerous situation for yourself, other boats or people.



ANCHOR ONLY IN AREAS WHERE YOUR BOAT WILL NOT HINDER OTHER BOATS.

DO NOT ANCHOR IN A CHANNEL!

Before anchoring the boat, stop the engine. If an anchor windlass is fitted, consult the manufacturer's manual.

When anchoring be aware that the condition of the sea bed, changes in tide, wind strength and direction and currents will affect the position of the craft. Use local landmarks to obtain an approximate fix for the craft's position and check this regularly.

When not in use, ensure the anchor and line are stored in the anchor locker.



OPERATING THE CRAFT

MOORING

Use the right, left cleats and bow towing eye for mooring.



Fig. 43. Bow cleat.

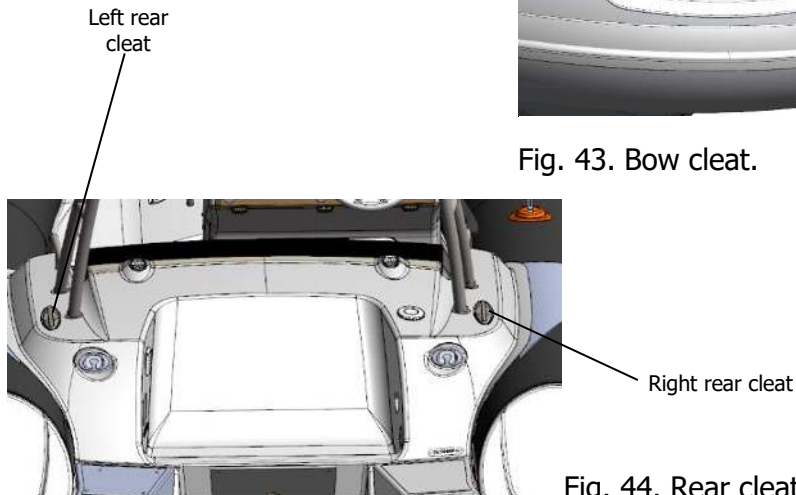

Fig. 44. Rear cleats.



When the boat is on land/davit, the cockpit drain plugs should remain open. This will ensure rain water does not accumulate in the boat.

Breaking strength, kN	
Bow cleat	11
Rear cleat	10

CAUTION

THE BREAKING STRENGTH OF LINES SHALL IN GENERAL NOT EXCEED 80% OF THE BREAKING STRENGTH OF THE RESPECTIVE STRONG POINT.

CAUTION

BE VERY CAREFUL WHEN MOORING: ARMS AND LEGS MAY BE INJURED IF THEY ARE OUTSIDE THE BOAT.

DON'T USE SAFETY HANDS, RAILS, HANDRAILS, STEERING WHEEL FOR MOORING.



OPERATING THE CRAFT

TOWING

When towing an inflatable boat behind another craft, always connect the tow line only to the towing eyes. It's forbidden to use handles, railings, cleats or other equipment which is not designated for towing.

If possible, use a double tow line when towing behind another boat. The second line acts as a backup in case one line breaks or comes undone.

Use a tow line of sufficient length so that there is at least two boat lengths between boats.

Use only line intended for towing, ask your Dealer for advice and select the correct line for your application (do not tow with three strand nylon rope).

A towed boat should always be observed. Tenders should not to be towed over long distances.

Do not use a tow line with signs of damage or wear. Check tow lines for wear and damage prior to use.

Always keep hands and feet clear of tow lines.



Be prepared to cast loose or cut the tow line if necessary.

Towing should be done at low speed.

Breaking strength of bow towing eye is 14 kN.

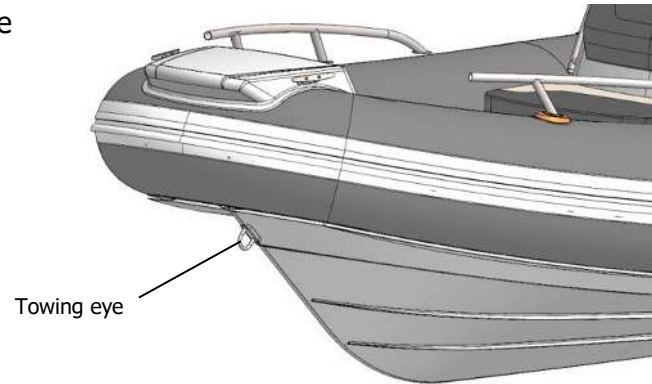

Fig. 45. Bow towing eye.

CAUTION

1. TOWING MUST BE DONE AT LOW SPEED (NOT MORE THAN 10 KM/H) AND IN GOOD WEATER CONDITIONS WITH NO WAVES.
2. THE BOAT BEING TOWED MUST BE OBSERVED AT ALL TIMES.
3. THE BREAKING STRENGTH OF LINES SHALL IN GENERAL NOT EXCEED 80% OF THE BREAKING STRENGTH OF THE BOW TOWING EYE.



OPERATING THE CRAFT

BEACHING

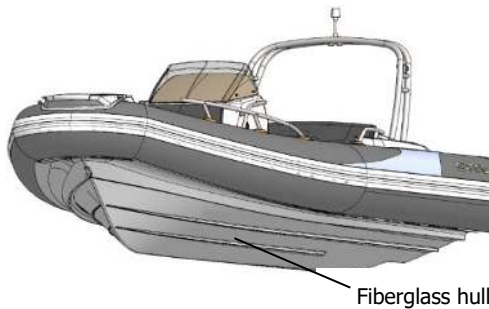

Fig. 46. Fiberglass hull.



NEVER DRAG THE BOAT OVER A ROUGH SURFACE (ROCKS, STONES, CONCRETE, ETC) AS THE HULL AND TUBE CAN EASILY BE DAMAGED.

Regularly check the surface of the fiberglass hull. If the gel coat is damaged, contact your Dealer for repair.

When approaching a beach or waters edge proceed slowly and with extreme caution.

Avoid hazards below the water surface such as rocks. Hazards can damage the hull, tube, motor, or propeller. Do not power the boat onto land as serious damage to the hull and tube may occur.

Do not drag the boat across rough or abrasive surfaces (rocks, concrete etc.). The hull and tube can be damaged.



5. TECHNICAL INFORMATION

TECHNICAL SPECIFICATION

See the table below for technical specifications of G500.

Model	G500LF	
Specification	Unit	
Length overall	cm	495
	ft/inches	16'3"
Length internal	cm	332
	ft/inches	10'11"
Beam width	cm	230
	ft/inches	7'7"
Width internal	cm	128
	ft/inches	4'2"
Chambers	Number	5
Tube diameter	cm	50
	inches	20"
Tube fabric		PVC/Hypalon
Bare boat weight*	kg	435
	lbs	957
Fully loaded weight**	kg	1515
	lbs	3340



TECHNICAL DETAILS

Loading capacity	kg lbs	1000 2205
Passenger capacity	Number	9
Maximum height (light craft)	m ft/inches	1.5 4'11"
Maximum draft (fully loaded), from hull's underside lowest point	m ft/inches	0.43 1'41"
Engine recommended	HP kW	90 66.2
Engine max	HP kW	115 84.6
Engine weight max	kg lbs	210 462
Engine shaft length	inches	20" (long)
Midsection / aft deadrise	degrees	21°/18°
Built-in fuel tank capacity	l	90
Water tank capacity (option)	l	50

Note:

- * - The bare boat weight is just a weight of the boat without any removable accessories.
- ** - Mass of the craft in the fully loaded condition (m_{LDC}).



STANDARD AND OPTIONAL EQUIPMENT

STANDARD FEATURES:

- Fiberglass deep-V hull with self-bailing anti-skid deck
- Anchor locker, bow and rear storage compartments
- Multi-chamber inflatable tube with handles and GRP steps
- Bow step plate with mooring cleat
- Steering console with windshield, seat and storage
- Dashboard for up to 9" screen, mechanical steering system and wheel
- Deck integrated rear seating sofa
- Set of seating cushions and backrests
- Inbuilt fuel system with 90lit / 23gal tank
- Integrated cupholders, handrails, cleats, towing & lifting eyes
- Pump, paddles and maintenance kit



TECHNICAL DETAILS

OPTIONAL EQUIPMENT:

- Navigation & waterski classic roll bar
- Rear swimming platforms with ladder and handrail
- Electrical package for boat & console
- Bow railings, on-tube installation
- Premium steering wheel
- Removable bow sundeck kit
- Removable bow sundeck extension kit
- Freshwater set with shower
- Canvas bimini-top, collapsible
- Overall and harbour covers
- SeaDek soft anti-skid flooring
- Keel & tube protector packages
- Black powder coated stainless steel upgrade
- Hi-prof. console with railing upgrade
- Overpressure valves



COMPARTMENT CHART

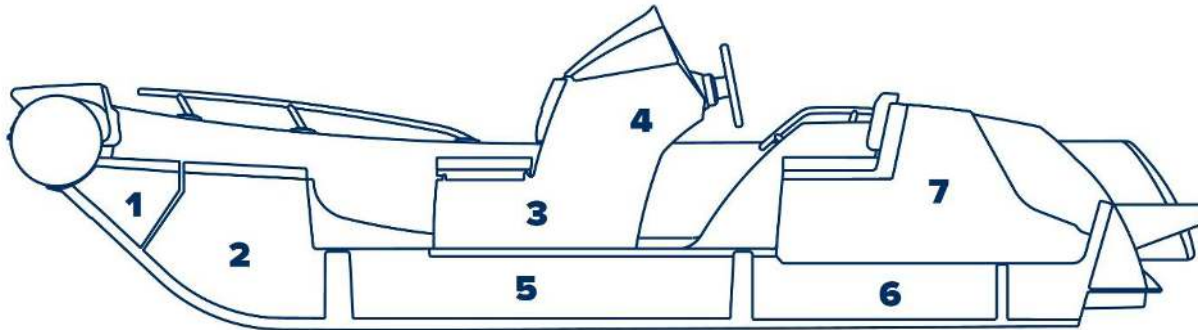

- | | |
|-------------------------|---------------------------|
| 1. Bow anchor storage | 5. Fuel tank compartment |
| 2. Bow locker | 6. Rear dry storage |
| 3. Console storage | 7. Rear lower compartment |
| 4. Glove box with hatch | |

Fig. 47. Compartment chart.



TECHNICAL DETAILS

GENERAL ARRANGEMENT OF A BOAT

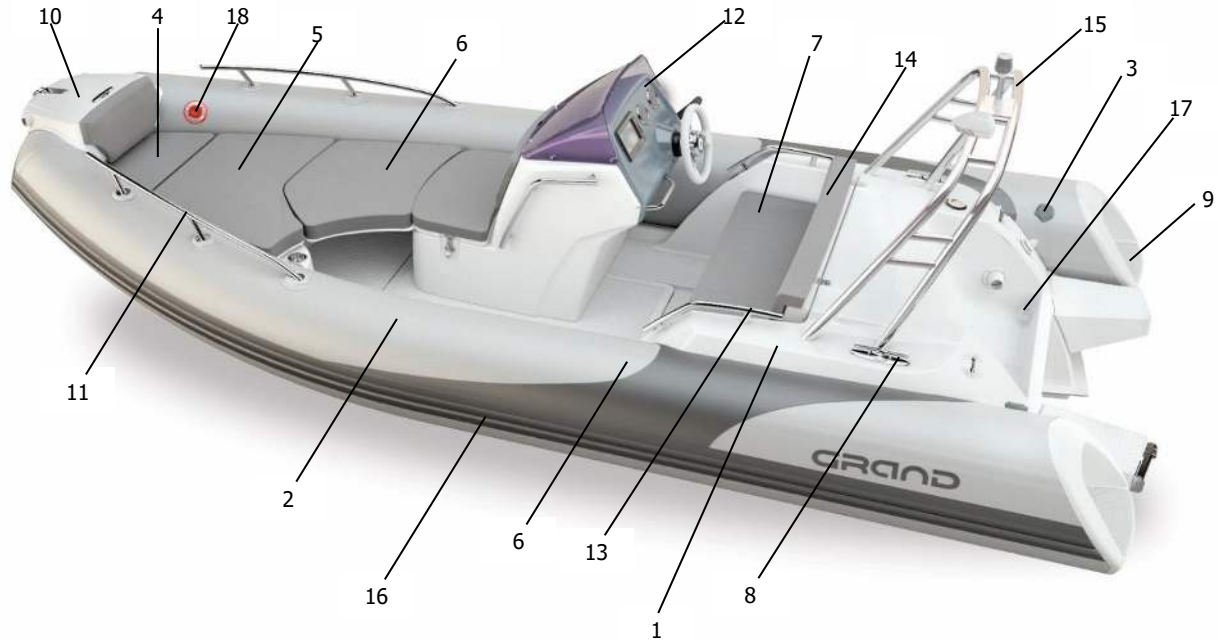

Fig. 48. General arrangement of a boat.



General arrangement of a boat (see fig. 48 on the previous page):

- | | |
|------------------------------|--------------------------------------|
| 1. Fiberglass hull | 10. Bow step plate |
| 2. Reinforced buoyancy tube | 11. Stainless steel bow railing |
| 3. Inflation/deflation valve | 12. Steering console CL-20 |
| 4. Bow cushion N°1 | 13. Rear seat extended handrails |
| 5. Bow cushion N°2 and hatch | 14. Rear seat back |
| 6. Bow sundeck with cushion | 15. Stainless steel navigation arch |
| 7. Rear seat with cushion | 16. Rubbing strake with splash guard |
| 8. Pull-up cleat | 17. Rear lifting eye |
| 9. Fiberglass step | 18. Overpressure valve |



STEERING CONSOLE COMPONENTS

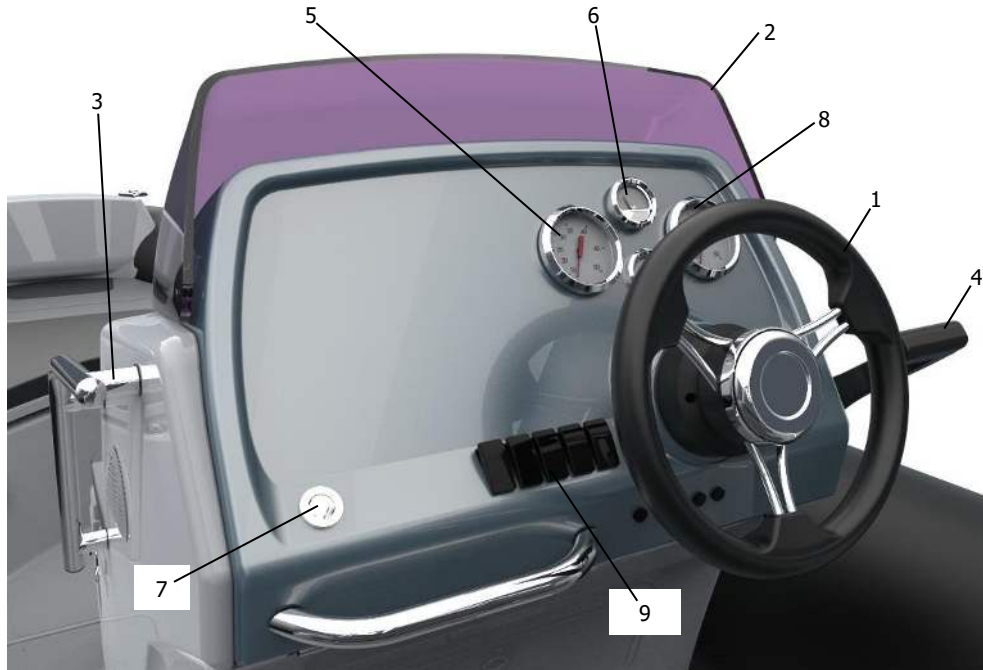

Fig. 49. Steering console components (see the list on the next page).



Steering console components (see fig. 49 on the previous page):

Steering system

Steering cable

Steering wheel (1)

Windshield (2)

Handrail (3)

Throttle lever (4) (optional*)

Speedometer (optional*) (5)

Fuel gauge (optional*) (6)

Double USB socket 5v (7)

Tachometer (optional*) (8)

Switches (9):

- Running light
- All-round light
- Horn
- Bilge pump
- Shower pump

When your trip is finished, always remove the key from the ignition switch. This will prevent theft or unauthorized use of your boat.

* - Please contact your regional Dealer for the installation of required components.



TECHNICAL DETAILS

GENERAL VIEW OF A BOAT

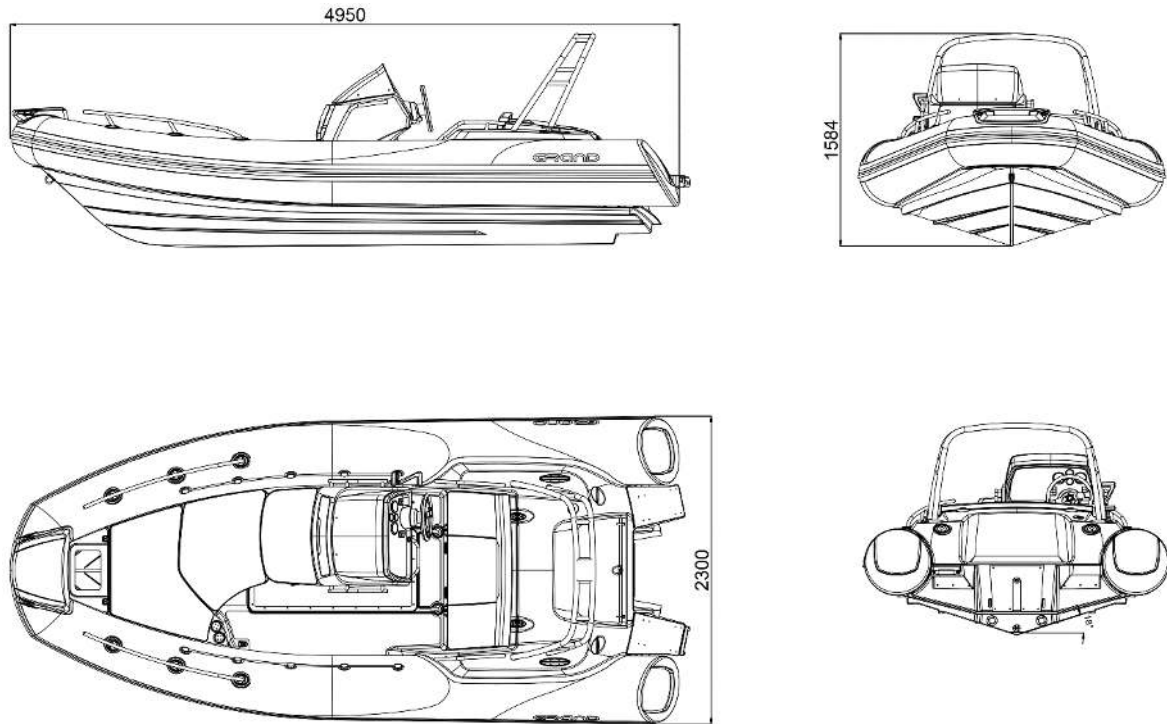

Fig. 50. General view of a boat.



ELECTRICAL SCHEMATIC DIAGRAMS

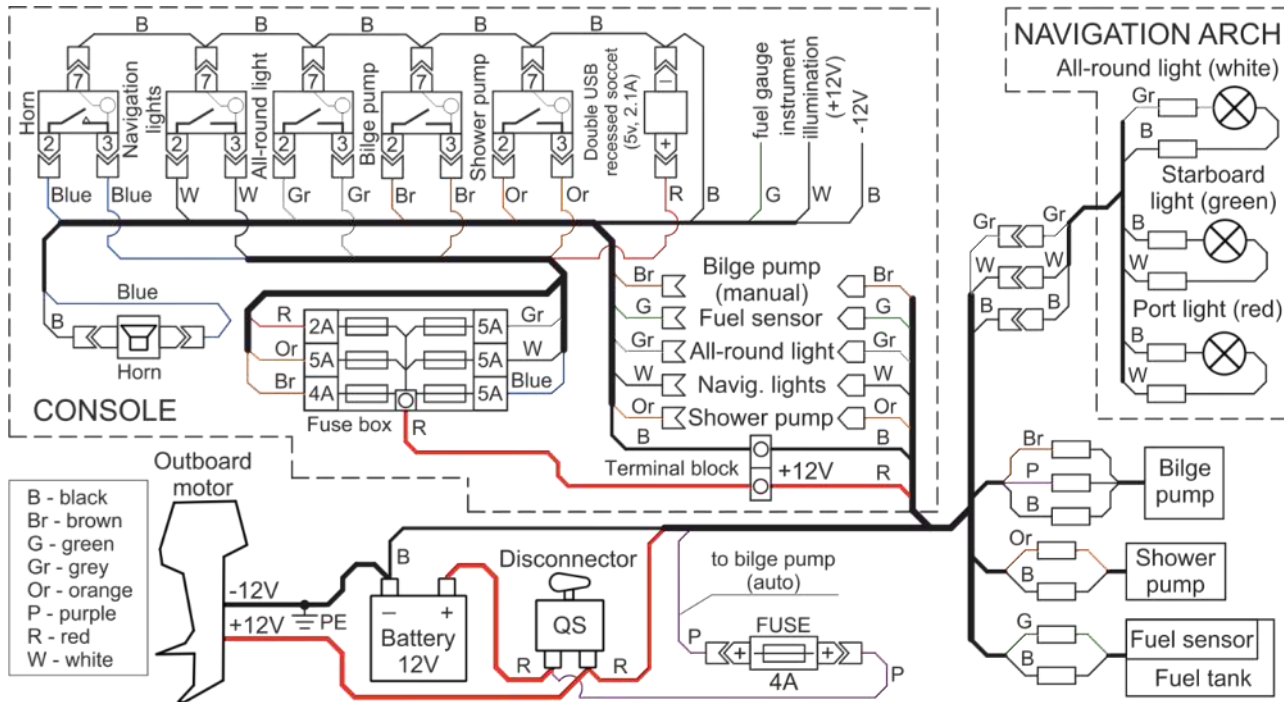

Fig. 51. Electrical schematic diagram for a boat with all navigation lights on the arch.



TECHNICAL DETAILS

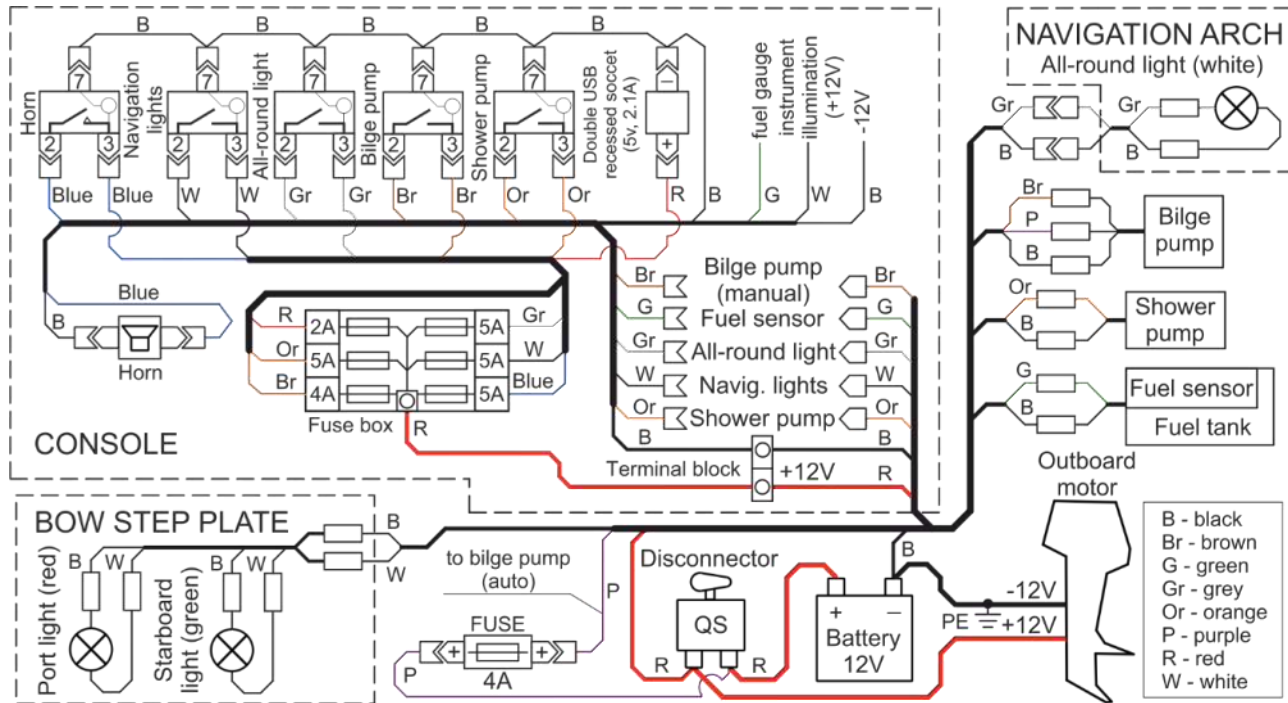

Fig. 52. Electrical schematic diagram for a boat with nav. lights on the arch and bow step plate.



6. SERVICE AND MAINTENANCE

Only high-quality materials suited for marine environments are used in production of our boats. Nevertheless, without a regular and proper maintenance, the moisture and saltiness inherent to this environment can reduce their service life.

Our advises about the maintenance of the boat is based on the recommendation of the manufacturers of the materials.

IMPORTANT NOTICE A dedicated cover for the whole boat is the best protection against UV degradation of gelcoat and fabric of the tube.



YOU SHOULD NOT USE STEAM BLASTERS AS THEY CAN AFFECT THE STRENGTH OF THE TUBE GLUED SEAMS.

NEVER USE A SANDBLASTING MACHINE FOR CLEANING.



SERVICE AND MAINTENANCE

CLEANING

- Regularly clean your boat and make sure this is done before winterizing.
- For cleaning use household cleaner (non abrasive) and fresh water only!
- At all times keep the inflatable tube, vinyl and other boat parts free of any chemical spills, such as:
 - Gasoline, grease, oil and any other oily product.
 - Suntan oils, lotions and any other body care products.
 - Pollution products, dirt and dust.
 - Silicon based products.
- If any of the above listed spills occur on the boat's surface clean and wash the boat or its relevant part as soon as possible, and only with approved liquids.
- When not in use keep your boat properly covered.
- Keep your boat away and properly protected against car's exhaust smoke pollution and heat: this may damage the boat.

IMPORTANT NOTICE We recommend to use cleaning agents specifically formulated for cleaning inflatable boats and RIBs.

A high-pressure washer can be used for cleaning the hull.



CAUTION

DON'T USE A HIGH-PRESSURE WASHER FOR TUBE WASHING.



CLEANING OF TUBE

An important factor for the long life of tube fabric is regular adequate cleaning.

The subsequent cleaning procedure is recommended:

- Rinse off with clear, tap water (approx. 20 °C).
- Use gentle soapy water (pH value neutral to slightly alkaline) to wash the tube by means of a soft cloth or brush. Do not leave the soapy water on the surface for more than 5 minutes.
- Clean the surface very thoroughly and make sure that no soap residue remains on the surface.
- Then dry by wiping off the surface with a soft cloth.

CLEANING THE UNDERWATER PART OF THE TUBE

Place the boat on a stand so that the underwater part of the tube is accessible.

To clean the part of the tube which is under water most of the time from the deposits, it is best to use a well-rounded wooden or plastic spatula.

While thoroughly wetting the surface, gently remove dirt, sand, algae, and other deposits.

A soapy solution or household detergent can be used. Then, rinse it thoroughly with fresh water. Wipe gently off with a soft cloth.



SERVICE AND MAINTENANCE



CAUTION

DO NOT USE THE FOLLOWING PRODUCTS TO CLEAN THE TUBE:

- Any cleaning device that might cause mechanical damage to the surface such as hard brushes, high-pressure washers, etc.
- Any cleaning agents (scouring agents or scrubbing powder), which will damage the surface;
- Strong alkaline cleaning agents.
- Acid cleaning agents.
- Solvent based cleaning agents (e. g. based on ester, ketone, ether, furan or benzol).
- Petrol, diesel, kerosene.
- Self-made cleaning agents.
- Bleaching or oxidizing cleaning agents (e.g. containing hydrogen peroxide, sodium hypochlorite, chlorine dioxide or sodium dithionite).



PLASTIC PRESERVATION

Surface quality may degrade by solar exposure, heat, salt deposits, anthropogenic pollution and vehicle exhaust gases.

The gelcoat surfaces will last a long time if regularly and properly cared for.

Keeping the surface clean and periodic waxing are key points in gelcoat care.

In the marine environment, protection of plastic surfaces must be applied more regularly than on your car because the sun is stronger and the horizon is longer than on shore.

Gelcoat care must be carried out in several stages.

CLEANING

The first step in any boat maintenance program is dirt removal. Use a detergent and a sponge specially dedicated for this purpose.

Rinse the sponge frequently in a separate bucket of water to prevent salt and dirt from moving around on gelcoat surface. Rinse the surface thoroughly with clean water and wipe it dry with a synthetic chamois or clean towel, just as you would wash your car.



SERVICE AND MAINTENANCE

SALT REMOVAL

If salt deposits are left on the gelcoat surface, it will look dull and stained even after polishing and waxing. To remove salt buildup, use the special agents or white vinegar. Rinse the surface thoroughly off with clean water when finished, and wipe dry with a synthetic chamois or clean towel.

POLISHING

Polishing is an important step in order to keep the gelcoat surface in good condition. Polishing should be done only by special pastes application. Polishing can be made manually or by using a slow-speed electric buffer. All works should be carried out on land when using a power tool. Polish no more frequently than is necessary, and then use the least abrasive material that will do the job.

WAXING

Use special waxes. Be sure to read the instructions before application. Preferably choose the time to work or position the boat so you can work in the shade, both to keep the surface cool and to keep from going blind.

IMPORTANT NOTICE According to the manufacturer's recommendation, the gelcoat surface should be waxed at least twice a year.



CLEANING OF THE UNDERWATER PART OF THE HULL FROM DEPOSITS

Cleaning with a high-pressure washer

The best means for removing stubborn deposits is a high-pressure washer.

However, when using a high-pressure washer, use it carefully so that the jet does not hit the tube.



CAUTION

THE USE OF A HIGH-PRESSURE WASHER TO CLEAN THE TUBE IS PROHIBITED. THE TUBE FABRIC CAN BE DAMAGED.

Cleaning with a spatula

To clean the fiberglass hull, place the boat on a stand so that most of the bottom is accessible. It is best to use a wooden or metal spatula with a flat tip. While thoroughly wetting the surface, gently remove dirt, sand, algae, and other deposits.

ANTIFOULING HULL PROTECTION

After the hull has been washed and well dried, apply an antifouling paint, if necessary.

Before working with antifouling paint, read carefully the instruction for use it.



SERVICE AND MAINTENANCE

UPHOLSTERY CARE

All upholstery of your boat is made from high quality coated fabrics.

Keeping upholstery dry and clean will not only maintain its appearance but also extend its life.

It's a good practice to clean it once a week. For deeper cleaning use soft brush once a month.

Remove stains as quick as possible, preferably within 24 hours.

Use liquid hand soap and water (1 part soap to 9 parts water), cotton, flannel white cloth by cleaning the upholstery in circular motions. Dry well.

After each use of boat, all upholstery should be well dried.

REMEMBER

Light colors upholstery should be maintained more attentively and more often.



CAUTION

- Do not use pressure washing
- Do not use powdered abrasives
- Do not use solvents, acetone, whiteners, waxes, silicones and other harsh chemicals

STORAGE

If you don't use the boat, take care to cover all upholstery to protect it from environment hazards.

During the storage, be sure about free air circulation around the cushions.



ACRYLIC GLASS WINDSHIELD CARE

Only clean water and soft microfiber, cotton or flannel cloth should be used for acrylic glass windshield cleaning.

To remove stubborn stains, use only cleaners formulated specifically for cleaning acrylic surfaces.



TO PREVENT SCRATCHES, DAMAGE, TURBIDITY AND OTHER DEFECTS:

- Do not make dry cleaning
- Do not use rough sponges or papers
- Do not use powdered abrasive cleaners
- Do not use harsh chemicals like petrol, acetone, ammonia-based cleaners, solvents (provoke cracks formation), alcohol, and alcohol-based liquids, etc.



SERVICE AND MAINTENANCE

AIRTIGHTNESS OF THE INFLATABLE TUBE

The tube is considered to be airtight if it retains the recommended inflation pressure for 8 hours.

- As the inflatable tube is a primary safety feature - check the airtightness of your boat regularly. Inspect the condition of all inflatable components and remember that some natural release of pressure (see the information below) can occur. Make sure that:
- There are no material cracks, holes and leaks.
- All inflation valves and seams are intact.
- According to ISO 6185 standard a 20% drop in pressure within 24 hours is not critical.
- If you discover a small reduction in pressure add some air using the foot pump supplied.



WARNING

NEVER USE HIGH-PRESSURE EQUIPMENT TO INFLATE YOUR BOAT.

Changes in ambient temperature have a significant influence on air pressure within the tube. A variation of 1°C results in a variation in pressure of about +/- 4 mb (0,06 psi).



IN CASE OF AN AIR LEAKAGE

If a significant drop of pressure has occurred, make a visual check of the tube:

- Step 1 - check the inflation/deflation valves and overpressure valves - *if there is no contamination and all seals are in good state.*
- Step 2 - check the major seams.
- Step 3 - check the tube material from top to bottom.

If you are not able to see any obvious sources of leakage, in way to find a defect, first inflate all tube compartments to nominal pressure, then spray a soapy solution on all surfaces including tube material, main seams and valves. In a leakage spot the air bubbles should be appeared. Mark the location of the defect with a pencil. No pen or marker can be used! You will be not able to remove their traces.

Remember to rinse thoroughly the soap solution-treated areas off with clean water after the checking is over.

Any source of leakage must be properly repaired.

Contact your Dealer for advice if necessary.



CAUTION

DO NOT OPERATE YOUR BOAT IF THE PRESSURE DROP IN THE TUBE IS MORE THAN 20% PER DAY.



SERVICE AND MAINTENANCE

MAINTENANCE OF STAINLESS STEEL

We use only top-quality stainless steels, which are resistant to corrosion. However, this may not be permanent and maintenance is sometimes required so:

- Avoid contamination and scoring to the surface.
- Frequently wash with fresh water.
- Once the surface is dry, apply some Vaseline or a dedicated grease for stainless steel and buff up to a high gloss by a rag.
- If you see a sign of rust – clean and mirror polish the area as soon as possible.

WINTERIZING AND STORAGE

IMPORTANT NOTICE Clean and wax the gelcoat surface prior to placing it in storage.

When storing your boat, keep it in a clean and dry place so it is not affected by major temperature fluctuations and other conditions. You may store the boat assembled and partly inflated with a cover so as to protect it from direct sunlight, dirt, dust and pollution.

- For winterizing:
 - Clean and dry the boat, including seat cushions and any plywood components.
 - Completely drain all water from the hull and bilge compartment.
 - Disconnect and remove the battery.
 - Grease all metal moving parts and connections, including steering.
 - Properly close the fuel system to avoid any vapour leaks.
 - If possible, allow air to circulate within the boat, a breathable canvas cover will help.



Winterize the motor, following the manufacturer's instructions.

CAUTION

1. WHEN THE BOAT IS IN STORAGE MAKE SURE IT IS COVERED.
2. STORE THE BOAT AWAY FROM RODENTS.
3. AVOID SHARP FOLDS IN THE TUBE MATERIAL.

REGULAR INSPECTIONS

- Check frequently all navigation lights, horn, VHF radio (if fitted), safety handles, handrails and all other safety related equipment.
- Check frequently the tightness of various screws, bolts and nuts, with particular attention to those holding the engine onto the transom. Also check all steering system components are secure and functioning correctly.
- Regularly examine your fuel system, replace old or damaged components and check the tightness of the fuel line connections.

DANGER

REGULARLY CHECK THE TIGHTNESS OF THE ENGINE TRANSCOM BOLTS AS THEY MAY BE AFFECTED BY VIBRATION.



TRAILERING

7. TRAILERING

The size and carrying capacity of the trailer should be suitable for the size and weight of your boat including the engine. Do not use a trailer that is too big or too small for your boat.

Use a BUNK trailer. Make sure that the trailer provides adequate support for the keel because basis weight of the boat is to be supported by the keel. Lateral bunks should be used just for extra support and stability. Reference dimensions are indicated on the figure 54-55.



The boat is designed to be transported with an inflated tube.

Fig. 53. Trailer.



CAUTION

DO NOT USE A ROLLER TRAILERS, AS ROLLERS DO NOT PROVIDE ADEQUATE SUPPORT FOR THE HULL.

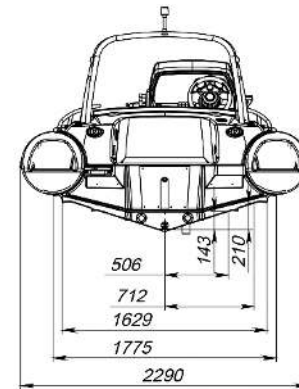
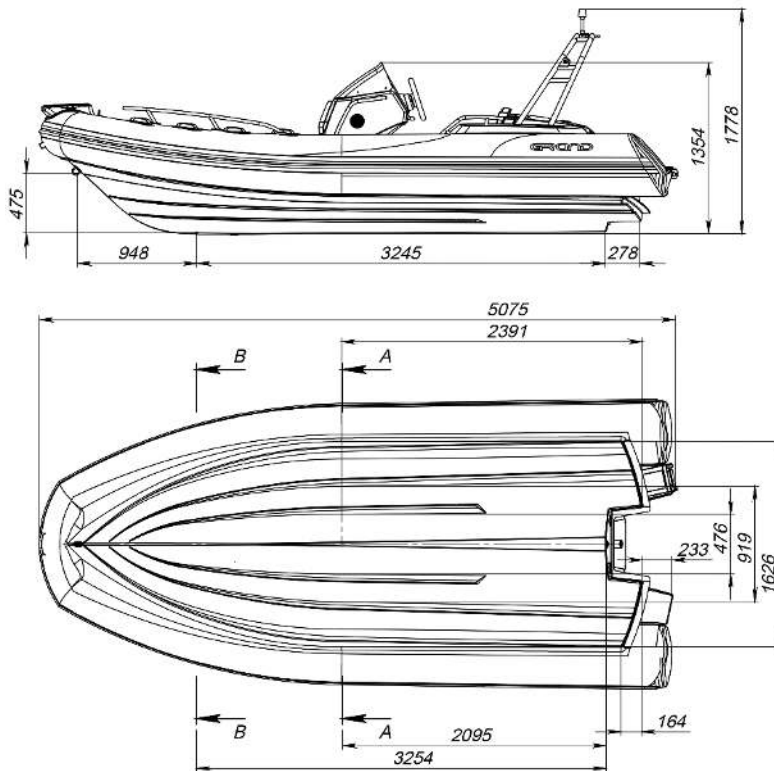

Note. All dimensions are in mm.

Fig. 54. Measurements for a correct trailer.

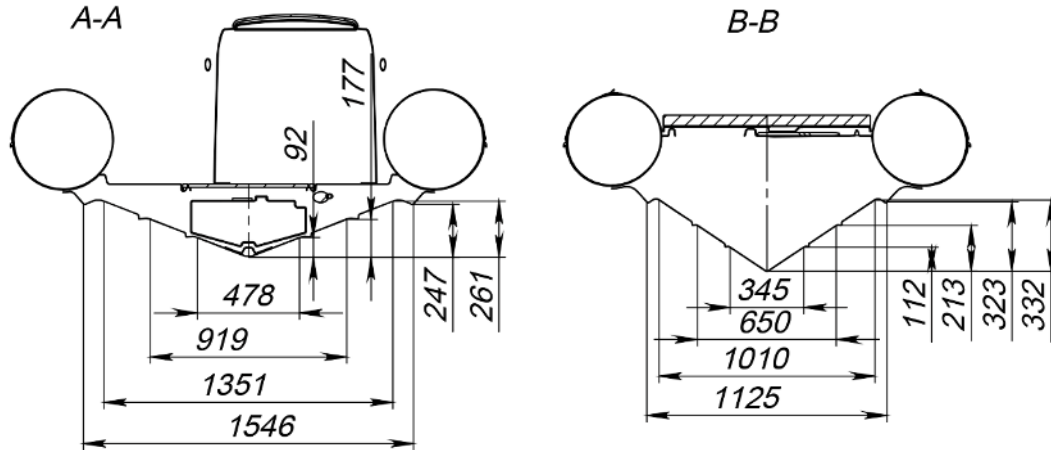

Note. All dimensions are in mm.

Fig. 55. Measurements for a correct trailer. Sections A-A and B-B.



BOAT TOWING

Before towing your boat, please refer to the trailer manufacturer's manual and also note the following:

- Make sure that the trailer provides adequate support for the keel and bunks that provide large contact areas for the hull.
- The boat is properly inflated and the cockpit drain plugs are open.
- Haul the boat onto the trailer using the bow eye.
- Make sure that the outboard engine leg is in the "trailing position". Refer to manufacturer's manual.
- Secure the boat to the trailer with suitable straps or rope, using bow, lateral and rear eyes for this purpose.
- Close and secure all hatches and openings on the boat. Cushions must be placed in lockers or removed to prevent loss during transit.

IMPORTANT NOTICE

Do not trailer the boat with the overall cover in place, it is not designed for transportation.



8. RESPECTING THE ENVIRONMENT

REMEMBER THAT RESPONSIBLE BOATING BEGINS WITH YOU!

Respect your environment by applying the following basic rules:

- AVOID CREATING EXCESSIVE WASH.
- KEEP OUT OF DESIGNATED SWIMMING AREAS.
- RESPECT ALL ANIMAL LIFE.
- BE CAREFUL NOT TO OVERFILL THE FUEL TANK.
- DON'T MAKE UNNECESSARY NOISE.
- DO NOT DISCHARGE OIL OR FUELS INTO THE WATER.
- DO NOT LITTER.

The health of our environment depends on us all acting responsibly to ensure a clean tomorrow. If each of us follows these few simple rules, we can help to keep the Earth's resources intact for future generations.



9. GRAND'S WARRANTY

GENERAL

Subject to the terms and conditions detailed below, Grand Marine Corporation warrants that Grand Inflatable Boats are free from defects in material or workmanship for the defined warranty period, and will, at its option, repair or replace defective parts on return of the craft to the premises of an Authorised Grand Reseller.

This warranty applies to new Grand Inflatable Boats purchased from an Authorised Grand Marine Reseller.

By using the Grand Inflatable Boats, the owner and helmsman understands and agree to undertake all instructions in the Grand Owner's Manual, and agrees to all warranty and liability terms and conditions contained in this warranty.

WARRANTY PERIOD

Grand warrants Grand branded components from the date of purchase for a period of:

- 24 consecutive months for normal personal recreational use*.

* - Normal recreational use is defined as not more than 100 annual return trips with not more than 100 annual outboard hours. Greater annual usage than this is not covered by the Grand recreational warranty.



WARRANTY

WARRANTY COVERAGE

The Grand warranty covers the following:

- Grand hull and its appropriated hull components.
- Inflatable tubes.

This warranty is limited to repair, or at Grand option, replacement of parts suffering from any of the defects described above during the warranty period. The judgment of Grand is final concerning the extent of items covered under above warranty.

The outboard engine, electrical and electronic components, other auxiliaries are subject of the warranty of the appropriate Manufacturer.

The warranty is not applicable in case the boat was not used for recreational purposes.



WARRANTY EXCLUSIONS

Grand warranty does not cover the following:

- Replacement of parts due to normal wear and tear.
- Routine maintenance parts and services, including but not limited to, maintenance requirements, oil and lubrication, replacement of fuses or bulbs, linkage adjustments, filters and spark plugs, tyres, and other consumable items.
- Damage caused by not following procedures and recommendations in the Grand Owner's Manual.
- Operating the craft beyond the design category.
- Damage caused by improper or lack of maintenance, winterization or storage.
- Damage caused by abuse, impact, accident, misuse, abnormal use or strain, neglect, racing, improper operation or operation not in accordance with the recommended procedures described in the Grand Owner's Manual.
- Damage or cosmetic changes due to exposure to the atmospheric or environmental conditions, including mould or marine organisms, or outside galvanic activity.
- Damage resulting from tears, punctures, abrasions, abuse, external damage, accident, submersion, water ingestion or contamination, fire, theft.



WARRANTY

WARRANTY CERTIFICATE

Name of Customer: _____

Address: _____

City: _____ Post code: _____

E-mail _____ Phone number: _____

WIN (Serial number): _____

Signature: _____

Dealer address: _____

City: _____ Post code: _____

Date of purchase: _____

Seller and customer acknowledge by signing that seller handed and customer received hereinbefore boat including standard (optional, if relevant) equipment and manual in English and that the boat is without evident defects.

SELLER SIGNATURE:

CUSTOMER SIGNATURE:

FOR YOUR NOTES

GRAND

INFLATABLE BOATS

Potemkina str. 18a, Solonicevka 62370,
Dergachevsky distr., Kharkovskaya obl.,
UKRAINE

Tel: +380 57 7840125

Tel/fax: +380 57 7840124

www.grandboats.com

mail@grandmarine.com.ua



Scan & visit
our official
website &
social media